| RESEARCH ARTICLE

Remote Working during the Covid-19 Global Pandemic and its Implications for Employee Motivation: Some Evidence from Nigeria through the Lens of Self-Determination Theory

Charles Nwoko¹ ✉ | Khashayar Yazdani²

^{1,2}*Malaysia University of Science & Technology, Block B, Encorp Strand Garden Office, No. 12, Jalan PJU 5/5, Kota Damansara, 47810 Petaling Jaya, Selangor, Malaysia*

Corresponding Author: Charles Nwoko, **E-mail:** charles.nwoko@phd.must.edu.my

| ABSTRACT

Following the outbreak of the COVID-19 pandemic, governments around the world took several safety measures, including enforced confinement to check the spread of the disease. These measures had economic, health, and psychosocial implications. On the other hand, the pandemic accelerated remote working and the deployment of technology to support this new way of working as businesses needed to continue functioning. Empirical research on the implication of these measures on the mental health, engagement, and motivation of employees abound in other jurisdictions, whereas it is limited in Nigeria. From a self-determination perspective, this study examines the mediating roles of organizational factors (OF) and employee's individual situation (ES) on employee motivation during the pandemic. The study employed a survey research design while descriptive statistics, exploratory factor analysis, and structural equation modelling were used to analyze the data. Remote working intensity (RW) during the pandemic had a significant positive impact on organizational factors. Employee's Individual Situation had a significant positive impact on Employee Motivation (EM). The study concludes that as good as remote working may seem, the enforced confinement led to increased stress levels, more mental health challenges, and lower motivation. The moderation role of basic psychological needs (PN) satisfaction was confirmed. The findings showed that employees who could influence their work schedule were more motivated. Higher levels of support from employers that enabled individuals to achieve desired results amidst the uncertainties created by the pandemic were also associated with better levels of motivation. Employees in organizations that found innovative ways for social connection and had regular check-ins by managers were more engaged and motivated because employers' support was found to be empowering, produced better psychological health, and helped employees feel self-determined. Even though the study shows the association between remote working, basic psychological needs satisfaction, and employee motivation, how motivation level changes after some point or the degree to which it would change in the post-pandemic era remains unclear and should be an area for further study since motivation is not a unitary phenomenon.

| KEYWORDS

Remote working, COVID-19, Nigeria, employee motivation; basic psychological needs, self determination

| ARTICLE DOI: [10.32996/jbms.2022.4.2.31](https://doi.org/10.32996/jbms.2022.4.2.31)

1. Introduction

The COVID-19 global pandemic brought fear, panic, anxiety, and alteration in people's ways of life. Several measures were taken to cope with its ravaging effect (Mahmoud-Saleh & Karia, 2020). Some of the measures taken to curtail the spread of the pandemic included quarantine and social distancing created other problems such as loneliness and social isolation (Grigoropoulos and Daoultzis, 2022). The pandemic had health, social and economic implications. Efforts to address one of these had implications for the others.

According to Van Zoonen et al. (2021), a number of factors came into play as a result of remote working – structural factors (independence and job clarity), relational factors (trust and social isolation), work contextual factors (location and how work is

performed) and communication factors (using communication technology to adjust to remote work). As self-isolation and social distancing became ubiquitous practices and were embraced as the new trend (Nagel, 2020; Vindegaard & Benros, 2020), it became important to investigate the impact of social isolation on employee motivation. Knowledge of the impact of social isolation on vulnerable individuals will be helpful to organizations and governments of the world in formulating post-COVID-19 policies needed to actualize the UN Sustainable Development Goal (SDG) 3 (Good Health & Well-Being) in light of the recent global health pandemic.

The lockdown policies adopted by governments to contain the spread of the pandemic unintentionally led to an economic recession globally (Singh, Singh, Houssein & Ahmad, 2020). Motivation and direction suffer due to economic recession (Eich, 2012). With remote working, there is a loss of personal connection, which cannot be replaced using technology (Oliver, Murphy & Cox, 2010; Evans & Bray, 2016). The most recent global pandemic before COVID-19, according to Arnold (2018), was the Spanish flu of 1918. This reportedly led to an outbreak of murder-suicides due to the depression. With the recent loss of jobs, pay freeze, financial uncertainties, loss of loved ones, etc., we can expect a repeat of the aftermath of the 1918 Spanish Flu. The actions taken by organizations and the managers within organizations have a critical role to play in helping employees navigate these difficult times and adjust to remote work. Van Zoonen et al. (2021) see this adjustment as an overall adaptation to environmental demands and conditions in which employees' satisfaction with the conditions of remote work, job performance due to remote work, and work-life balance are key considerations.

Considering that the COVID-19 pandemic affected countries around the world (Dayrit & Mendoza, 2020; Burke, D., & Cocoman, 2020), including Nigeria, it is important to assess the relationship between remote working and employee motivation during the pandemic in the Nigerian context. This is important knowing that empirical research on the impact of the COVID-19 on business and mental health abound in other jurisdictions, whereas studies on the subject are limited in Nigeria.

1.1 Current Research Gap

Ryan (2012) adduced three reasons for the renewed interest in the psychology of human motivation - the theoretical depth and interdisciplinary nature of the field; methodological innovations that have opened up new avenues of inquiry, and the practical importance of motivation research as translational science and for improving individual and community wellness through empirically supported interventions. He further posits that, beyond the theoretical perspectives of motivation and social psychology, there is a range of modern issues and unanswered questions that research on work motivation needs to address, namely motivation of people in groups and organizations, motivation over some period, motivation as well as creativity, and the effects rewards have. Some of these unanswered questions provide a gap which is part of the motivation for this study. Also, most documented studies on the application of the self-determination theory of motivation have been in developed economies and, more importantly, during times outside of a global pandemic.

Wang et al. (2020) believe that what is known about remote working can be questioned in an extraordinary pandemic context. Therefore, this research aims to close an existing research gap in the application of the self-determination theory by examining the role of externally regulated remote working on motivation during the COVID-19 global pandemic from the lens of the self-determination theory. This study examines whether and how much the degree of autonomy, competence, and relatedness enjoyed by employees during the pandemic affected their motivation, i.e., considering the moderating role of basic psychological needs satisfaction. It also aims to identify the mediating roles played by organizational factors and individual employee situations.

According to Wang et al. (2020), the challenges of remote work challenges mirror workers' immediate psychological experiences in accomplishing tasks. It is also about their interpersonal collaborations and social interactions with family and friends. Given that remote working has come to stay, building on the existing body of knowledge and closing the existing research gap on this subject is an academic imperative.

2. Literature Review

2.1 Theoretical Framework

This study has the Self-Determination Theory (SDT) as its theoretical framework. The theory originated from the work by Edward Deci and Richard Ryan and was first made popular in their book: "Self-Determination and Intrinsic Motivation in Human Behavior" published in 1985. SDT suggests that people are motivated by fulfillment and growth needs. According to Ryan and Deci (2017), human behaviors are influenced in large part by personal and contextual motivational factors. The theory believes that psychological growth is driven by three components – autonomy, competence, and relatedness.

Autonomy simply means the need for self-volition, personal choices, and critical thinking. It exists when people feel they are in control of their own goals and behavior. People are motivated when they can take actions that result in changes either in their

work or other aspects of life. According to Legault (2017), autonomy is embedded in the need for an individual to experience self-direction and personal endorsement in action.

Competence is about a person learning skills and having the capability needed for success and seeing oneself as being able to overcome difficult challenges.

Relatedness is about connection, attachment, belonging, being cared for, and caring for others.

Szulawski, Izabela, and Prusik (2021) believe that these three basic psychological needs (autonomy, competence, and relatedness) contribute to the development of a human being’s intrinsic motivation towards striving, well-being, and performance.

According to Ryan and Deci (2000), most research on the effects of environmental events on intrinsic motivation has focused largely on the issue of autonomy versus control rather than that of competence. Motivation is a psychological construct used to describe the mechanism by which individuals and groups decide on behaviour and persist with it (Boddy, 2012). It is about investigating the energization and direction of behaviour (Deci & Ryan, 1985). Energy is at the core of human needs and consists of the needs to be met for humans to remain healthy and those obtained from interacting with one’s environment. On the other hand, behaviours are the methods by which humans respond to internal and external stimuli (Cantarero, van Tilburg & Smoktunowicz, 2020). Motivation is about the why of behaviour. The concept of human behaviour and motivation is well explained by the self-determination theory. The core of the theory is the conditions that support or hinder human success in general and in specific areas of human endeavours, including education, parenting, work, psychotherapy, and wellbeing. These conditions could be social, cultural, or biological. Šakan, Žuljevic, and Rokvic (2020) believe that basic psychological needs are essential nutrients of well-being and that a person’s basic psychological needs (need for autonomy, need for competence, and the need for relatedness) must be satisfied for the person to be fully functional.

Ryan and Deci (2017) believe that even though the human inclination to be motivated intrinsically is innate, this natural tendency could be readily diminished in many contexts such that persons who otherwise might be active become passive. This is important in the context of the new normal where people work remotely. In order to explain this disparity, research on Self-Determination Theory has extensively investigated the effect of social context on intrinsic motivation against the backdrop of the hypothesis that some social conditions support active engagement whereas others thwart it. Legault (2017) posits that Self-Determination theory is premised on the belief that the individual is involved in a dynamic interaction with the environment continuously. This interplay between the person and the environment makes people become either engaged, curious, and connected or demotivated, ineffective and detached. Ryan and Cornell (1989) believe that one central issue for motivation theories relates to the perceived locus of the variables that cause behaviour relative to the person. The concept known as perceived locus of causality (PLOC) was introduced by Heider (1958) in reference to the phenomenal analysis of how a person infers the motives and intentions of others. He concluded that there were two causations – personal causation (due to a person’s intention) and impersonal causation (when the environment produces a given effect independent of a person’s intentions).

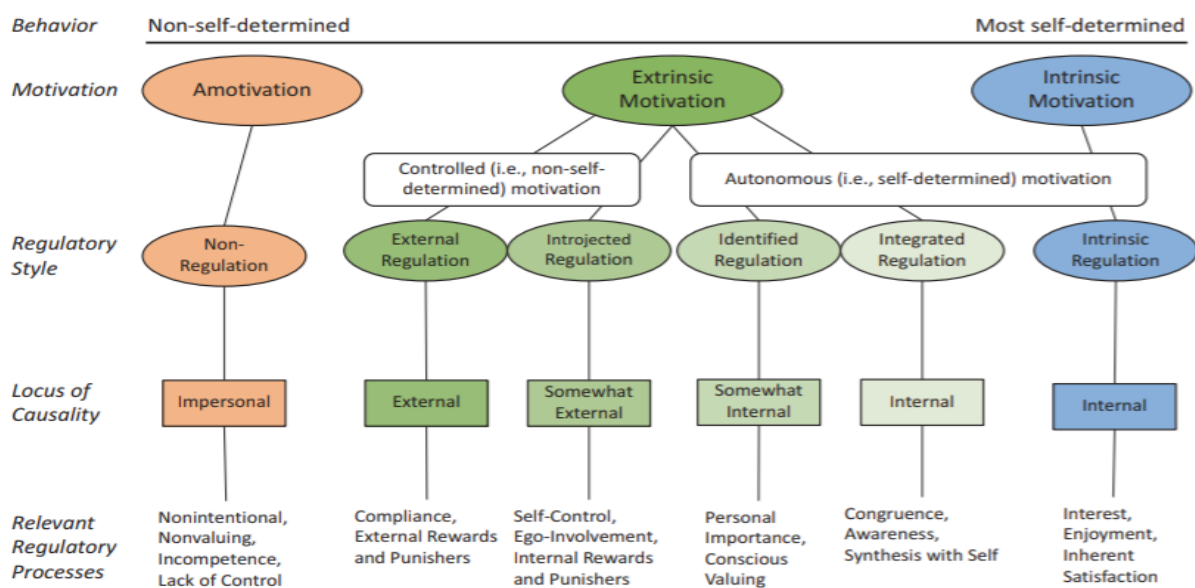

Figure 1: The internalization continuum according to self-determination theory (Source: Legault, 2017)

In relation to Figure 1 above, enforced confinement or lockdown measures, as seen during the pandemic, is an example of external regulation requiring compliance. Violation invoked punishment. This controlled, non-self-determined behaviour with an external perceived locus of causality could lead to demotivation.

2.2 Employee Motivation in Nigeria

Scholars have argued that organizations in developing societies (including Nigeria) may not be perceived as places where decent salaries are paid or where strong motivation toward work exists, even though these organizations are institutions with a high need for achievements that are socially relevant (Tauringana, 2020; Erin & Adegboye, 2021). Most studies on employee motivation in Nigeria focus on the relationship between motivation and productivity (Funso, Sammy & Gerryshom, 2016; Forson et al., 2021). Forson et al. (2021) concluded that job motivation factors showed a positive and significant effect when regressed on job performance.

The challenge for managers is how to motivate employees to perform better. In the study by Funso, Sammy & Gerryshom (2016), they found that what motivates employees varies. While supervisors are mostly motivated by financial rewards (good pay, bonus, promotion, etc.), contractors prefer non-financial incentives. Similarly, Alhassan (2020) found that salaries, promotion, and training each have a direct relationship with performance. Also, motivation can direct behaviour towards specific goals, improve effort and energy, increase cognitive processing and lead to improved performance, among others. Sule et al. (2015) believe that poor wages and salaries are a persistent cause of frustration and may lead to a decline in productivity. Wages and salaries are considered adequate when they satisfy employees' economic, psychological, growth, and motivational needs.

Just like in any other country, employees in Nigeria are motivated by rewards. Therefore, it is imperative that employers create a competitive environment to reward their employees (Gerged, Beddewela & Cowton, 2021). While some employees are motivated by extrinsic rewards, including pay, promotion, and bonus, others prefer appreciation, praise, and recognition (Nwobu & Iyoha, 2018; Nuskiya, Ekanayake, Beddewela & Gerged, 2021). In a study in Nigeria by Tamunosiki-Amadi & Dede (2015) on self-determination and employee innovative behaviour, they found that there exists a significant positive relationship between self-determination and each of the following: idea generation, idea development, and idea implementation. They concluded that employees need authority and autonomy to undertake their tasks and that where employees have autonomy, competence and skills are brought to bear in the promotion of new ideas, innovation, and work process reengineering.

2.3 COVID-19 Pandemic in Nigeria and Remote Working

When, where, and how employees' work has been disrupted by the COVID-19 crisis (Guido, Pichierri, Rizzo, Chieffi & Moschis, 2020; Hamdan-Mansour, Al Shibi, Khalifeh, & Hamdan-Mansour, 2020). Ajayi (2020) believes that many corporate organizations operating in Nigeria were averse to remote working prior to the outbreak of the COVID-19 pandemic. According to Nagel (2020), many executives have thought of flexible work arrangements before the COVID-19 pandemic without much action. However, following the outbreak of the pandemic, the choice was between whether to stop operations completely or establish remote working practices. Businesses in Nigeria have since gotten on board with remote working.

Researchers posit that remote working has created new challenges for organizations. One of such challenges is how to maintain a culture when most or all employees are distributed virtually and may not be employed in the traditional settings that existed prior to COVID-19 (Malhotra, 2021). Another concern is around employee benefits and allowances that would enable them to work optimally from home against the backdrop of poor infrastructure in some countries, the handling of data protection and data security, and re-negotiating the terms of employment contracts (Gethin-Jones, 2014; Offord, 2020). In a 2020/2021 Survey of Top 10 Business Risks conducted by KPMG Nigeria, one new risk that made it to the list was Business Continuity Risk. This is the risk of a business being able to recover or continue to deliver products or services at an acceptable level following a crisis or disruptive event. COVID-19 has been identified as one disruptive event that could jeopardize the continuity of businesses in Nigeria.

3. Purpose

Deci and Ryan (1985) suggest that motivation is about energizing and directing behaviour. Motivation practices are wrapped up in the societal and organizational culture. With uncertainties, fear, and stress arising from the COVID-19 pandemic and the ensuing government-imposed lockdowns, understanding what motivates employees who work remotely is critical. This is what this study is about, especially since this is the biggest pandemic in the past one hundred years. The understanding from this study will be critical when implementing remote working strategies even in the post-pandemic era.

The applicability of the self-determination theory has not been examined during a period of enforced confinement. Based on this knowledge, this study examines (1) the relationship between remote working and organizational factors; (2) how organizational

factors affect employee motivation considering the moderating role of basic psychological needs satisfaction; (3) the association between remote working and employee individual situation and (4) how employees' individual situation affects their motivation.

The main hypothesis for this study is in accordance with a previous study by Patanjali & Bhatta (2022) that suggests that autonomy, empowerment, and other organizational factors, including independence to employees and a supportive environment, are important enablers even in a remote working context.

4. Methodology

4.1. Research Design and Data Collection Method

This study adopted a survey research design because it affords the researcher the opportunity to gather quantitative data conveniently and economically from a large number of respondents (Saunders, Lewis & Thornhill, 2009). Data collection was also aided using a questionnaire.

4.2. Population and Sample Selection

The population of the study refers to all items or subjects that possess the characteristics or have knowledge of the phenomenon being investigated (Neuman, 2014). A population can thus be defined as the group of individuals/firms/companies from which the study seeks to generalize its findings (Kumar, 2011). The target population for this study is professionals, white-collar workers based in Nigeria. However, a sample of one hundred and two (102) respondents was randomly selected from amongst members of the Alliance Manchester Business School Alumni Association and the Chartered Institute of Management Accountants (all in Nigeria). The study employed purposive sampling, which is about getting all possible cases that fit the set criteria using various approaches. The reason for this approach is that the sample frame for the study is unknown, and the sample size is ambiguous (Buallay & Al-Ajmi, 2020). Furthermore, given the need for greater diversity, this sampling technique enables the use of judgment in deciding the cases that meet the set requirements and can answer the research questions and deliver on the research objectives (Adel, Hussain, Mohamed & Basuony, 2019). Diversity in this study was achieved along various dimensions: across different organizations and geographical locations. Prior studies have used a similar approach to achieve diversity (e.g., Perego & Kolk, 2012; Farooque & Ahulu, 2017; Lu & Wang, 2021). The respondents' profiles showed that 55% and 45% were male and female, respectively.

4.3 Research Instrument and Measurement of Variables

The research instrument used for this study is structured questionnaires. The use of structured questionnaires is consistent with the research design discussed above, which entails a survey as a way of gathering data from respondents. Considering the sample size and the inherent advantages, self-administered, fully structured questionnaires were selected. Hyman et al. (2019) agree that self-administered questionnaires are a relatively quick and cost-efficient way to collect large data from diverse and representative samples.

The questionnaire was divided into six sections. Four parts were developed using a Likert five-point scale with the aim of obtaining information relating to the independent, mediating, and moderating variables being considered. Specifically, these cover questions about remote working, organizational factors, basic psychological needs satisfaction, and individual employee circumstances that affect their motivational outcomes. The fifth session is to gather general information about employees' disposition to remote working. The last part is to gather personal and demographic data about the respondents. All the questions were based on factors and observed variables from previous studies. Measurement of variables is presented in Appendix 1.

4.4 Results

4.4.1 Validity and Reliability

Validity was ensured by adapting measurements in literature to measured variables. An additional check on validity was established by conducting an exploratory factor analysis to check the loading of items of variables (Tavakol & Wetzel, 2020). The results of the test are reported in **Tables 4.1 to 4.6**.

4.4.2 Remote working during COVID-19 pandemic (RW)

The results of the Exploratory Factor Analysis (EFA) test are reported in **Tables 4.1a to 4.1d**.

Table 4.1a: KMO and Bartlett's Test

Kaiser-Meyer-Olkin Measure of Sampling Adequacy.	.547
Bartlett's Test of Sphericity	Approx. Chi-Square
	26.772
	df
	15
	Sig.
	.031

Table 4.1b: Communalities

	Initial	Extraction
1. Employees in my organization frequently worked from home before the COVID-19 pandemic	1.000	.789
2. In my organization, employees worked primarily from home during the COVID-19 pandemic	1.000	.578
3. Physical meetings are more effective compared to virtual meetings	1.000	.635
4. Remote working had an effect on my work role and scope	1.000	.746
5. It was easy for my organization to switch from working in the office to working remotely	1.000	.655
6. My organization is willing to allow employees to continue working remotely in the post-pandemic era	1.000	.751

Extraction Method: Principal Component Analysis.

Table 4.1c: Total Variance Explained

Component	Initial Eigenvalues			Extraction Sums of Squared Loadings		
	Total	% of Variance	Cumulative %	Total	% of Variance	Cumulative %
1	1.667	27.783	27.783	1.667	27.783	27.783
2	1.483	24.716	52.499	1.483	24.716	52.499
3	1.004	16.726	69.225	1.004	16.726	69.225
4	.678	11.300	80.526			
5	.650	10.832	91.358			
6	.519	8.642	100.000			

Extraction Method: Principal Component Analysis.

Table 4.1d: Component Matrix^a

	Component		
	1	2	3
1. Employees in my organization frequently worked from home before the COVID-19 pandemic	.543	.201	-.674
2. In my organization, employees worked primarily from home during the COVID-19 pandemic	.633	.411	-.094
3. Physical meetings are more effective compared to virtual meetings	-.491	.596	.197
4. Remote working had an effect on my work role and scope	-.238	.790	-.256
5. It was easy for my organization to switch from working in the office to working remotely	.727	-.126	.334
6. My organization is willing to allow employees to continue working remotely in the post-pandemic era	.384	.528	.570

Extraction Method: Principal Component Analysis.

a. 3 components extracted.

The significant p-value of 0.031 in **Table 4.1a** confirms the factorability of Remote Working (RW) as a variable. The table of communalities (**Table 4.1b**) shows that the items measuring RW have a high degree of extraction, as the item with the least extraction is .578 (or 57.8%). The total number of variances explained stood at 69.225% (**Table 4.1c**). Since component 1 has the highest degree of variance explained, we assess the factor loading in component 1. In **Table 4.1d**, 3 items loaded above a 0.50 threshold for exploratory factor analysis (Items 1,2, and 5). These 3 items were therefore retained for further analysis of measures of Remote Working during the COVID-19 pandemic (RW). The other items loading below the threshold were disregarded as they do not strongly measure the variable, RW.

4.4.3 Organisational factors (OF)

Table 4.2a: KMO and Bartlett's Test

Kaiser-Meyer-Olkin Measure of Sampling Adequacy.		.596
Bartlett's Test of Sphericity	Approx. Chi-Square	96.956
	df	36
	Sig.	.000

Table 4.2b: Communalities

	Initial	Extraction
7. I depend on others to perform my work tasks	1.000	.767
8. The COVID-19 pandemic accelerated the speed of deployment of remote working technology in my organization	1.000	.612
9. My supervisor/manager set clear expectations for me while I worked from home during the pandemic	1.000	.725
10. Compared to working in the office, I had fewer opportunities to request or receive informal performance feedback during the pandemic	1.000	.880
11. Managing employees working remotely during the pandemic is different from managing employees working within the same office	1.000	.637
12. My leader trusts that I will put in my best even though I work remotely	1.000	.601
13. In my organization, employees' motivation levels changed during the COVID-19 pandemic	1.000	.778
14. Adequate IT tools and equipment were provided by my organization to support employees working from home during the pandemic	1.000	.800
15. The level of support provided by my organization towards employee mental health during the COVID-19 pandemic was satisfactory	1.000	.667

Extraction Method: Principal Component Analysis.

Table 4.2c: Total Variance Explained

Component	Initial Eigenvalues			Extraction Sums of Squared Loadings		
	Total	% of Variance	Cumulative %	Total	% of Variance	Cumulative %
1	2.745	30.505	30.505	2.745	30.505	30.505
2	1.437	15.962	46.467	1.437	15.962	46.467
3	1.279	14.211	60.678	1.279	14.211	60.678
4	1.006	11.179	71.856	1.006	11.179	71.856
5	.772	8.581	80.437			
6	.572	6.357	86.794			
7	.529	5.881	92.675			
8	.404	4.486	97.161			
9	.256	2.839	100.000			

Extraction Method: Principal Component Analysis.

Table 4.2d: Component Matrix^a

	Component			
	1	2	3	4
7. I depend on others to perform my work tasks	.396	-.129	.454	-.623
8. The COVID-19 pandemic accelerated the speed of deployment of remote working technology in my organization	.720	.152	-.012	.267
9. My supervisor/manager set clear expectations for me while I worked from home during the pandemic	.368	.756	-.104	-.082
10. Compared to working in the office, I had fewer opportunities to request or receive informal performance feedback during the pandemic	-.007	.289	.739	.501
11. Managing employees working remotely during the pandemic is different from managing employees working within the same office	.523	.141	.538	-.233
12. My leader trusts that I will put in my best even though I work remotely	.694	-.033	-.344	.018
13. In my organization, employees' motivation levels changed during the COVID-19 pandemic	.372	-.648	.183	.431
14. Adequate IT tools and equipment were provided by my organization to support employees working from home during the pandemic	.752	-.463	-.074	-.120
15. The level of support provided by my organization towards employee mental health during the COVID-19 pandemic was satisfactory	.691	.294	-.264	.184

Extraction Method: Principal Component Analysis.

a. 4 components extracted.

The significant p-value of 0.000 in **Table 4.2a** confirms the factorability of Organisational Factors (OF) as a variable. The table of communalities (**Table 4.2b**) shows that the items measuring OF have a high degree of extraction, as the item with the least extraction is .601 (or 60.1%). The total number of variances explained stood at 71.856% (**Table 4.2c**). Since component 1 has the highest degree of variance explained, we assess the factor loading in component 1. In **Table 4.2d**, 5 items loaded above a 0.50 threshold for exploratory factor analysis (Items 8,11,12,14, and 15). These 5 items were therefore retained for further analysis. The other items loading below the threshold were disregarded as they do not strongly measure the variable.

4.4.4 Basic psychological needs satisfaction (PN)

Table 4.3a: KMO and Bartlett's Test

Kaiser-Meyer-Olkin Measure of Sampling Adequacy.	.647
Bartlett's Test of Sphericity	Approx. Chi-Square
	168.361
	df
	36
	Sig.
	.000

Table 4.3b: Communalities

	Initial	Extraction
"17. My organization provided adequate communication and information sharing during the pandemic."	1.000	.744
"18. I found the frequency of check-in sessions and employee follow-up during the pandemic satisfactory."	1.000	.739
"19. My organization provided assurance to employees that their jobs were secured during the pandemic."	1.000	.677
"20. My organization allowed employees to decide their work schedule while working remotely during the pandemic."	1.000	.670
"21. The income I received from my employer changed during the COVID-19 pandemic."	1.000	.740

"22. I was independent and personally responsible for my work while working from home."	1.000	.894
"23. My organization provided adequate training on how to use remote working and collaboration tools in order to assist my transition to working from home."	1.000	.527
"24. My supervisor/line manager was easily accessible to discuss any issues I had while working from home during the COVID-19 pandemic."	1.000	.606
"25. In my organization, we introduced some innovative measures to ensure social interaction amongst employees working remotely during the pandemic."	1.000	.671

Extraction Method: Principal Component Analysis.

Table 4.3c: Total Variance Explained

Component	Initial Eigenvalues			Extraction Sums of Squared Loadings		
	Total	% of Variance	Cumulative %	Total	% of Variance	Cumulative %
1	3.608	40.094	40.094	3.608	40.094	40.094
2	1.585	17.612	57.706	1.585	17.612	57.706
3	1.074	11.936	69.642	1.074	11.936	69.642
4	.802	8.908	78.550			
5	.651	7.236	85.787			
6	.492	5.471	91.258			
7	.356	3.954	95.212			
8	.276	3.065	98.277			
9	.155	1.723	100.000			

Extraction Method: Principal Component Analysis.

Table 4.3d: Component Matrix^a

	Component		
	1	2	3
"17. My organization provided adequate communication and information sharing during the pandemic."	.771	-.281	.266
"18. I found the frequency of check-in sessions and employee follow-up during the pandemic satisfactory."	.804	-.190	-.238
"19. My organization provided assurance to employees that their jobs were secured during the pandemic."	.759	-.313	-.055
"20. My organization allowed employees to decide their work schedule while working remotely during the pandemic"	.384	.467	-.551
"21. The income I received from my employer changed during the COVID-19 pandemic."	.000	.849	-.142
"22. I was independent and personally responsible for my work while working from home."	.216	.539	.747
"23. My organization provided adequate training on how to use remote working and collaboration tools in order to assist my transition to working from home."	.635	.317	-.154
"24. My supervisor/line manager was easily accessible to discuss any issues I had while working from home during the COVID-19 pandemic."	.776	-.055	.035
"25. In my organization, we introduced some innovative measures to ensure social interaction amongst employees working remotely during the pandemic."	.771	.199	.193

Extraction Method: Principal Component Analysis.

a. 3 components extracted.

The significant p-value of 0.000 in **Table 4.3a** confirms the factorability of Basic Psychological Needs Satisfaction (PN) as a variable. The table of communalities (**Table 4.3b**) shows that the items measuring PN have a high degree of extraction, as the item with the least extraction is .527 (or 52.7%). The total number of variances explained stood at 69.642% (**Table 4.3c**). Since component 1 has the highest degree of variance explained, we assess the factor loading in component 1. In **Table 4.3d**, 6 items loaded above a

0.50 threshold for exploratory factor analysis (Items 17,18,19,23,24 and 25). These 6 items were therefore retained for further analysis. The other items loading below the threshold were disregarded as they do not strongly measure the variable.

4.4.5 Employee's individual situation (ES)

Table 4.4a: KMO and Bartlett's Test

Kaiser-Meyer-Olkin Measure of Sampling Adequacy.	.715
Bartlett's Test of Sphericity	Approx. Chi-Square
	204.874
	Df
	66
	Sig.
	.000

Table 4.4b: Communalities

	Initial	Extraction
"26. My family situation affected my work schedule and performance while working from home."	1.000	.564
"27. I put in more hours into my work because I saved some commuting time by working from home instead of the office."	1.000	.500
"28. Working from home created anxiety and stress for me."	1.000	.628
"29. The process of transiting from working in the office to working from home was challenging for me."	1.000	.538
"30. I had my dedicated personal workspace, which I did not have to share with others whilst working from home."	1.000	.454
"31. I felt socially isolated whilst working from home during the pandemic."	1.000	.744
"32. Working from home allowed me more time to attend to personal and family needs."	1.000	.570
"33. I find the indoor environmental quality at home conducive for the performance of my work."	1.000	.799
"35. I had better work-life balance while working from home compared to when I worked in the office."	1.000	.673
"36. I got support towards my work from my family member(s) while working from home."	1.000	.629
"37. Given my personal and family situation, I would prefer to continue working from home."	1.000	.599
"38. Caring for children and other family members while working from home affected my productivity."	1.000	.283

Extraction Method: Principal Component Analysis.

Table 4.4c: Total Variance Explained

Component	Initial Eigenvalues			Extraction Sums of Squared Loadings		
	Total	% of Variance	Cumulative %	Total	% of Variance	Cumulative %
1	4.262	35.516	35.516	4.262	35.516	35.516
2	1.660	13.833	49.349	1.660	13.833	49.349
3	1.059	8.829	58.178	1.059	8.829	58.178
4	.993	8.278	66.456			
5	.932	7.763	74.219			
6	.784	6.531	80.750			
7	.695	5.792	86.542			
8	.605	5.045	91.587			
9	.352	2.933	94.519			
10	.295	2.460	96.979			
11	.195	1.624	98.603			
12	.168	1.397	100.000			

Extraction Method: Principal Component Analysis.

Table 4.4d: Component Matrix^a

	Component		
	1	2	3
"26. My family situation affected my work schedule and performance while working from home."	-.710	.212	.120
"27. I put in more hours into my work because I saved some commuting time by working from home instead of the office."	.069	.703	-.033
"28. Working from home created anxiety and stress for me."	-.551	.529	-.210
"29. The process of transiting from working in the office to working from home was challenging for me."	-.594	.348	.253
"30. I had my dedicated personal workspace, which I did not have to share with others whilst working from home."	.195	.184	-.618
"31. I felt socially isolated whilst working from home during the pandemic."	-.671	.501	.206
"32. Working from home allowed me more time to attend to personal and family needs."	.575	.113	.475
"33. I find the indoor environmental quality at home conducive for the performance of my work."	.844	.293	-.022
"35. I had better work-life balance while working from home compared to when I worked in the office."	.719	.044	.392
"36. I got support towards my work from my family member(s) while working from home."	.647	.435	.147
"37. Given my personal and family situation, I would prefer to continue working from home."	.648	.372	-.204
"38. Caring for children and other family members while working from home affected my productivity."	-.455	-.078	.263

Extraction Method: Principal Component Analysis.
a. 3 components extracted.

The significant p-value of 0.000 in **Table 4.4a** confirms the factorability of the Employee's individual situation (ES) as a variable. The table of communalities (**Table 4.4b**) shows that the items measuring ES have a high degree of extraction, as the item with the least extraction is .283 (or 28.3%). The total number of variances explained stood at 58.178% (**Table 4.4c**). Since component 1 has the highest degree of variance explained, we assess the factor loading in component 1. In **Table 4.4d**, 5 items loaded above a 0.50 threshold for exploratory factor analysis (Items 32, 33, 35, 36, and 37). These 5 items were therefore retained for further analysis. The other items loading below the threshold were disregarded as they do not strongly measure the variable.

4.4.6 Employee Motivation

Table 4.5a: KMO and Bartlett's Test

Kaiser-Meyer-Olkin Measure of Sampling Adequacy.	.549
Bartlett's Test of Sphericity	Approx. Chi-Square
	15.462
	Df
	6
	Sig.
	.017

Table 4.5b: Communalities

	Initial	Extraction
"16. Employees in my organization were less engaged and committed while working remotely during the pandemic."	1.000	.853
"34. The flexibility of working from home improved my work performance."	1.000	.733
"43. I feel accomplished when given the opportunity to decide my work schedule."	1.000	.560
"44. My enthusiasm and dedication towards my job remain the same even when I work from home."	1.000	.549

Extraction Method: Principal Component Analysis.

Table 4.5c: Total Variance Explained

Component	Initial Eigenvalues			Extraction Sums of Squared Loadings		
	Total	% of Variance	Cumulative %	Total	% of Variance	Cumulative %
1	1.651	41.269	41.269	1.651	41.269	41.269
2	1.045	26.130	67.399	1.045	26.130	67.399
3	.759	18.982	86.381			
4	.545	13.619	100.000			

Extraction Method: Principal Component Analysis.

Table 4.5d: Component Matrix^a

	Component	
	1	2
"16. Employees in my organization were less engaged and committed while working remotely during the pandemic."	-.372	.846
"34. The flexibility of working from home improved my work performance."	.723	.459
"43. I feel accomplished when given the opportunity to decide my work schedule."	.713	.228
"44. My enthusiasm and dedication towards my job remain the same even when I work from home."	.694	-.260

Extraction Method: Principal Component Analysis.

a. 2 components extracted.

The significant p-value of 0.017 in **Table 4.5a** confirms the factorability of Employee motivation (EM) as a variable. The table of communalities (**Table 4.5b**) shows that the items measuring EM have a high degree of extraction, as the item with the least extraction is .549 (or 54.9%). The total number of variances explained stood at 67.399% (**Table 4.5c**). Since component 1 has the highest degree of variance explained, we assess the factor loading in component 1. In **Table 4.5d**, 3 items loaded above a 0.50 threshold for exploratory factor analysis (Items 34, 43, and 44). These 3 items were therefore retained for further analysis. The other items loading below the threshold were disregarded as they do not strongly measure the variable.

4.5 Reliability

Further analysis was conducted to assess reliability. Therefore, Cronbach alpha was used to assess reliability/ internal consistency. The result of the test is reported in **Table 4.6**.

Table 4.6: Reliability Test Result

Variable	No of items	Cronbach Alpha
RW	3	.656
OF	5	.718
PN	6	.839
ES	5	.795
EM	3	.653

From the result in **Table 4.6**, all items have a Cronbach alpha above the 0.6 recommended minimum to gauge internal consistency. Based on this result, it is concluded that internal consistency is not an issue (Shaughnessy, Zechmeister & Zechmeister, 2012).

4.6 Method of Data analysis

Descriptive statistical techniques such as frequency count, Mean, and standard deviation were used for analysis. Structural equation modelling was used to assess the interrelationship among variables.

4.7 Response Rate and Respondents' Profile

From the questionnaire distributed, 109 responses were received. However, seven (7) copies were unsuitable for use because of incomplete responses. The one hundred and two (102) valid responses were processed for analysis., This is considered adequate to perform statistical analysis. Descriptive statistics on variables are presented in **Appendix 2**.

4.8 Respondents' Profile

Analysis of respondents' profiles is presented in **Table 4.7a** to **Table 4.7f**.

Table 4.7a: No of subordinates supervised by Respondents

	Frequency	Percent	Valid Percent	Cumulative Percent
Valid 1	10	9.8	9.8	9.8
2	14	13.7	13.7	23.5
3	60	58.8	58.8	82.4
4	4	3.9	3.9	86.3
5 or more	14	13.7	13.7	100.0
Total	102	100.0	100.0	

Table 4.7b: Sector where respondents function

	Frequency	Percent	Valid Percent	Cumulative Percent
Valid IT/Telecom	16	15.7	15.7	15.7
Public Service/Social Service	6	5.9	5.9	21.6
Transport/Logistics	4	3.9	3.9	25.5
Manufacturing/Construction	4	3.9	3.9	29.4
Financial Services	34	33.3	33.3	62.7
Energy/Utilities	4	3.9	3.9	66.7
Professional Services (Law, Consulting, etc.)	10	9.8	9.8	76.5
Mining/Oil & Gas Exploration	10	9.8	9.8	86.3
Agriculture	2	2.0	2.0	88.2
Education	4	3.9	3.9	92.2
Not for Profit	2	2.0	2.0	94.1
Hospitality/Food/Leisure	2	2.0	2.0	96.1
Travel	2	2.0	2.0	98.0
Dredging	2	2.0	2.0	100.0
Fin tech	2	2.0	2.0	100.0
Total	102	100.0	100.0	

Table 4.7c: Cadre in organisation

	Frequency	Percent	Valid Percent	Cumulative Percent
Valid Junior	2	2.0	2.0	2.0
Middle	28	27.5	27.5	29.4
Management	56	54.9	54.9	84.3
Board	16	15.7	15.7	100.0
Total	102	100.0	100.0	

Table 4.7d: Work Area/ Location

		Frequency	Percent	Valid Percent	Cumulative Percent
Valid	Lagos	80	78.4	78.4	78.4
	Abuja	8	7.8	7.8	86.2
	Other locations	14	13.8	13.8	100.0
Total		102	100.0		

Table 4.7e: Gender

		Frequency	Percent	Valid Percent	Cumulative Percent
Valid	Male	56	54.9	54.9	54.9
	Female	46	45.1	45.1	100.0
Total		102	100.0	100.0	

Table 4.7f: No. of people in Respondents' households during the pandemic

		Frequency	Percent	Valid Percent	Cumulative Percent
Valid	1	6	5.9	5.9	5.9
	2	4	3.9	3.9	9.8
	3	34	33.3	33.3	43.1
	4	28	27.5	27.5	70.6
	5	30	29.4	29.4	100.0
Total		102	100.0	100.0	

The result in **Table 4.7a** shows that the majority, 60 (58.8%), of the respondents directly supervise 3 persons in their organization. The result in **Table 4.7b** shows respondents cut across various sectors of the Nigerian economy. However, a sizeable number (34) is from the financial services sector (33.3%). More than half of the respondents, 56 (54.9%), are in the management cadre, while a further 16 (15.7%) belong to Board-level management (see **Table 4.7c**). In **Table 4.7d**, we see that a sizeable number (80) of the respondents are based in Lagos, the commercial nerve centre of Nigeria (78.4%). Both Male (56 representing 54.9%) and Female (46, which is 45.1%) respondents were well represented in the study, as the responses obtained are not gender-biased (**Table 4.7e**). The number of people in respondents' households during the pandemic generally varied. However, most of the households had 3 members during the period (33.3%), going by the result in **Table 4.7f**. Taken together, the results in **Tables 4.7a to 4.7f** show that respondents were from diverse backgrounds in terms of gender, sector, level of responsibility at work and at home, work location, and cadre in the organization. These diversities provide a rich context to explore how remote working affects employee motivation during the COVID-19 pandemic.

4.9 Result from Model 1

The result from Model 1 on the complexity of the relationship between the variables is presented in **Figure 1** and **Table 8**

Figure 4.1: Model 1

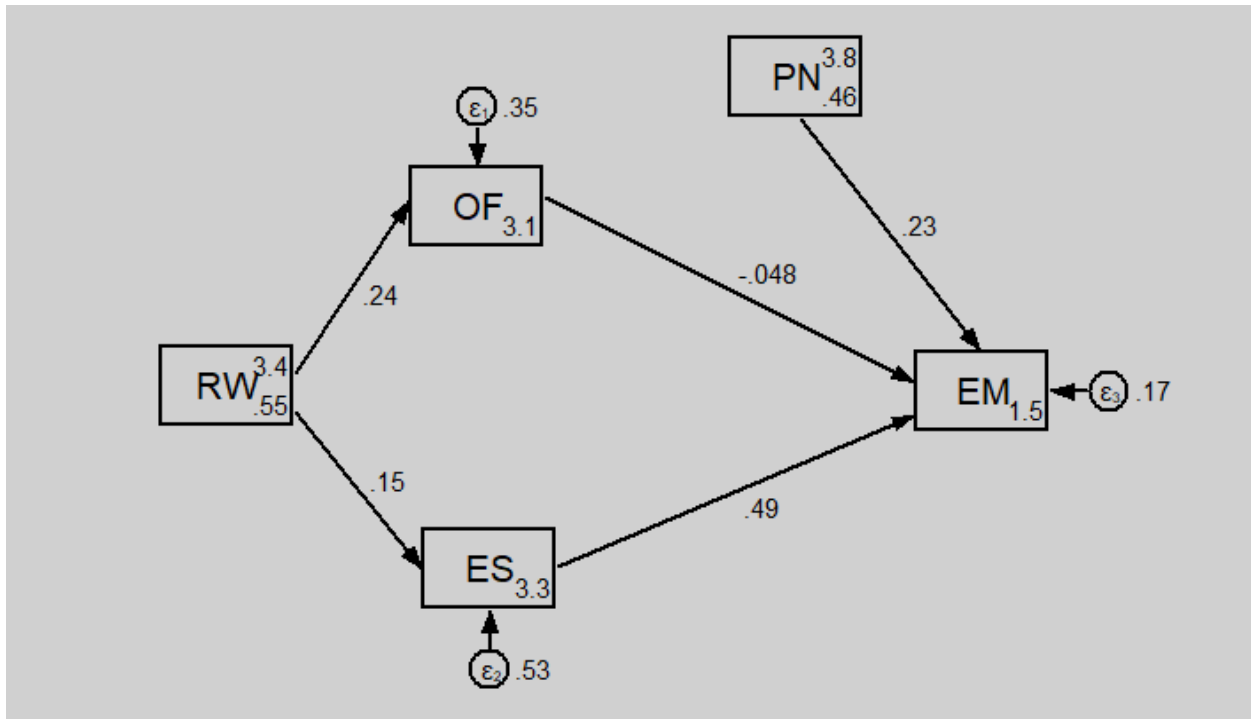

KEY: RW = Remote Working during COVID-19 pandemic; OF = Organisational factors; PN = Basic psychological needs satisfaction; ES = Employee’s individual situation; EM = Employee Motivation

Table 4.8: SEM result on Model 1

	OIM					
	Coef.	Std. Err.	z	P> z	[95% Conf. Interval]	
-----+-----						
Structural						
OF <-						
RW	.2449156	.11506	2.13	0.033	.0194022	.470429
_cons	3.050654	.402276	7.58	0.000	2.262208	3.839101
-----+-----						
ES <-						
RW	.1459297	.1422015	1.03	0.305	-.1327801	.4246395
_cons	3.305543	.497169	6.65	0.000	2.33111	4.279977
-----+-----						
EM <-						

OF	-.0482189	.1367918	-0.35	0.724	-.3163258	.2198881
ES	.4943334	.0849074	5.82	0.000	.3279179	.6607489
PN	.2322881	.1286951	1.80	0.071	-.0199496	.4845258
_cons	1.465022	.4631995	3.16	0.002	.5571675	2.372876

var(e.OF)	.3486044	.0711586		.2336588	.5200961
var(e.ES)	.5324669	.1086894		.3568962	.7944077
var(e.EM)	.1722703	.0351645		.1154674	.2570166

LR test of model vs. saturated: $\chi^2(4) = 35.73$, Prob > $\chi^2 = 0.0000$

From the result of Model 1 (**Table 4.8**), RW has a significant positive impact on OF with the regression coefficient at 0.2449156, and the p-value = 0.033 or 3.3% which is less than 5% (i.e., $p = 0.033 < 0.05$). In other words, the regression coefficient is statistically significant at 5%. The z value of 0.11506 implies the standardized value of the regression coefficient. The confidence interval of 0.0194022 to 0.470429 indicates the range of values that the regression coefficient (0.2449156) could assume. Taken together, the result shows that RW has a significant positive impact on OF. The error term of 0.3486044 for OF means that other factors, aside RW investigated in the study, are responsible for 34.86% of the variation in OF.

RW also has a positive impact on ES at 0.1459297; however, the impact is not statistically significant, although the range of the values for the coefficient is -0.1327801 to 0.4246395, and the z value is 1.03. The same interpretation applies to the relationship among other items indicated in the Model. In other words, RW does not significantly affect ES (since $p = 30.5\% > 5\%$), although RW has the potential to positively affect ES, going by the positive regression coefficient of 0.1459297. On the other hand, ES and PN have a significant positive impact on EM. Specifically, PN impacts ES at a coefficient of 0.4943334 and the impact is statistically significant ($p = 0.0000 < .05$). The range of values is also positive, moving from 0.3279179 to 0.6607489. With respect to the impact of PN on EM, the result is also statistically significant 0.2322881 ($p = 0.071 < .10$) with coefficient ranging from -0.0199496 to 0.4845258. The z value is also positive at 1.80.

However, the impact of OF on EM is negative and not statistically significant at -0.0482189. The coefficient also fluctuates around the value of -0.3163258 to 0.2198881, with a negative z value of -0.35.

To confirm the fitness of the model and the reliability of the result for Model 1, Model diagnostics were performed, and the result is presented in Table 9.

Table 4.9: Model 1 Robustness

Fit statistic	Value	Description
Likelihood ratio		
chi2_ms(3)	4.407	model vs. saturated
p > chi2	0.221	
chi2_bs(10)	80.008	baseline vs. saturated
p > chi2	0.000	
Population error		

RMSEA | 0.099 Root mean squared error of approximation

90% CI, lower bound | 0.000

upper bound | 0.280

pclose | 0.269 Probability RMSEA <= 0.05

-----+-----
 Information criteria |

AIC | 443.887 Akaike's information criterion

BIC | 471.955 Bayesian information criterion

-----+-----
 Baseline comparison |

CFI | 0.980 Comparative fit index

TLI | 0.933 Tucker-Lewis index

-----+-----
 Size of residuals |

SRMR | 0.082 Standardized root mean squared residual

CD | 0.161 Coefficient of determination

-----+-----
 A Chi-square p value less than 5%, Comparative Fit Index (CFI) and Tucker-Lewis Index (TLI) close to 0.95 (Hu & Bentler, 1999), a Root Mean Squared Error of Approximation (RMSEA) p value of < 0.05 (Schreiber et al., 2006), and a Standardized Root Mean Squared Residual (SRMR) close to 0 indicate good fit. The result in **Table 4.9** satisfies all the recommended thresholds, confirming model fitness (Chi-square p value = 0.000; CFI = 0.980; TLI = 0.933; RMSEA p < 0.05; SRMR = 0.082). This leads to the conclusion that the result is reliable.

4.10 Robustness check: Alternative Model 2

To assess the robustness of the result, an alternative Model (Model 2) is proposed, as presented in Figure 4.2 and Table 4.10

Figure 4.2: Model 2

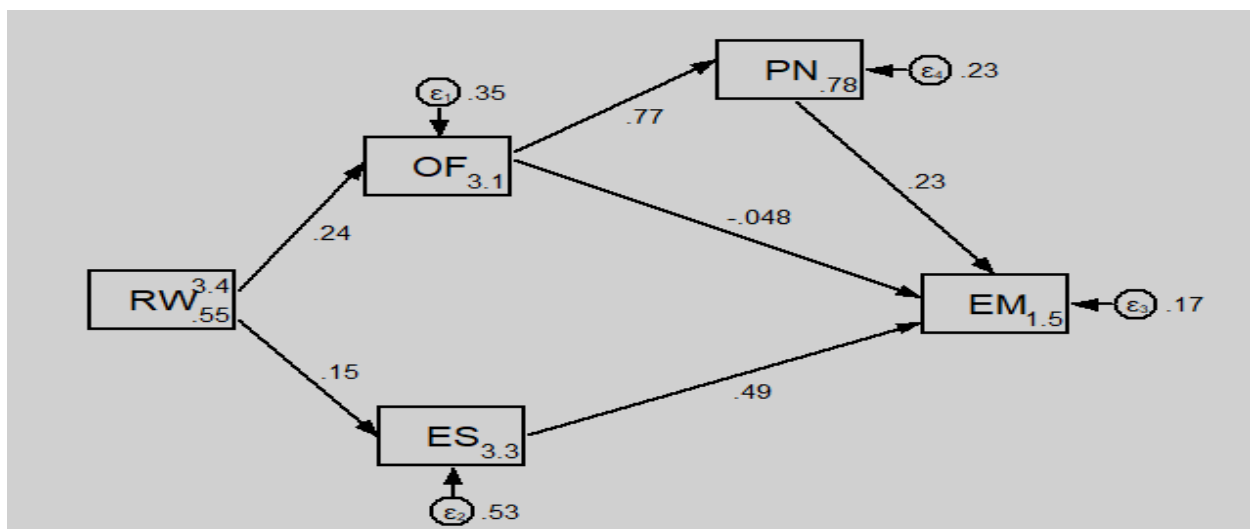

KEY: RW = Remote Working during COVID-19 pandemic; OF = Organisational factors; PN = Basic psychological needs satisfaction; ES = Employee’s individual situation; EM = Employee Motivation

Table 4.10: Model 2 Result

	OIM					
	Coef.	Std. Err.	z	P> z	[95% Conf. Interval]	
-----+-----						
Structural						
OF <-						
RW	.2449156	.11506	2.13	0.033	.0194022	.470429
_cons	3.050654	.402276	7.58	0.000	2.262208	3.839101
-----+-----						
ES <-						
RW	.1459297	.1422015	1.03	0.305	-.1327801	.4246395
_cons	3.305543	.497169	6.65	0.000	2.33111	4.279977
-----+-----						
EM <-						
OF	-.0482189	.1367918	-0.35	0.724	-.3163258	.2198881
ES	.4943334	.0849074	5.82	0.000	.3279179	.6607489
PN	.2322881	.1286951	1.80	0.071	-.0199496	.4845258
_cons	1.465022	.4631995	3.16	0.002	.5571675	2.372876
-----+-----						
PN <-						
OF	.7702116	.1126944	6.83	0.000	.5493347	.9910884
_cons	.7799692	.4435946	1.76	0.079	-.0894603	1.649399
-----+-----						
var(e.OF)	.3486044	.0711586			.2336588	.5200961
var(e.ES)	.5324669	.1086894			.3568962	.7944077
var(e.EM)	.1722703	.0351645			.1154674	.2570166
var(e.PN)	.2325691	.047473			.1558839	.3469787
-----+-----						

LR test of model vs. saturated: $\chi^2(4) = 7.53$, Prob > $\chi^2 = 0.1105$

In the alternative Model, the impact of OF on PN is examined by linking both variables through an arrow that flows from OF to PN. This permits the rigorous examination of how PN affects EM through the intervention of OF. The result shows that the impact of OF on PN is positive (0.7702116) and statistically significant ($p = 0.0000 < .05$). In other words, organizational factors engender the satisfaction of psychological needs. The alternative Model 2 is robust and consistent with the result of Model 1, in which RW

positively and significantly affects OF; ES has a significant positive impact on EM, and PN has a significant positive impact on EM. In addition, OF has a significant positive impact on PN.

The Model fitness statistics for the alternative model are presented in **Table 4.11**.

Table 4.11: Model Fit for Model 2

Fit statistic	Value	Description
Likelihood ratio		
chi2_ms(3)	4.407	model vs. saturated
p > chi2	0.221	
chi2_bs(10)	80.008	baseline vs. saturated
p > chi2	0.000	
Population error		
RMSEA	0.099	Root mean squared error of approximation
90% CI, lower bound	0.000	
upper bound	0.280	
pclose	0.269	Probability RMSEA <= 0.05
Information criteria		
AIC	443.887	Akaike's information criterion
BIC	471.955	Bayesian information criterion
Baseline comparison		
CFI	0.980	Comparative fit index
TLI	0.933	Tucker-Lewis index
Size of residuals		
SRMR	0.082	Standardized root mean squared residual
CD	0.161	Coefficient of determination

A Chi-square p value less than 5%, Comparative Fit Index (CFI) and Tucker-Lewis Index (TLI) close to 0.95 (Hu & Bentler, 1999), a Root Mean Squared Error of Approximation (RMSEA) p value of < 0.05 (Schreiber et al., 2006), and a Standardized Root Mean Squared Residual (SRMR) close to 0 indicate good fit. The result in **Table 4.11** satisfies all the recommended thresholds, confirming model fitness (Chi-square p value = 0.000; CFI = 0.980; TLI = 0.933; RMSEA p < 0.05; SRMR = 0.082). This leads to the conclusion that the result is reliable.

5. Discussion and Conclusion

This study is based on empirical evidence from the Nigerian context and employed a survey research design. Descriptive statistics, exploratory factor analysis, and structural equation modelling were used to analyze data. It presents remote working and its implications for employee motivation by looking at the mediating roles of organizational factors (such as employee mental health support and the provision of remote working resources) and the employees' individual situation (such as family situation, self-discipline, and feeling of loneliness). The study points to the differences between behaviours that are externally motivated and those that are intrinsic. Notwithstanding this distinction, intrinsic and extrinsic motivation are additive and synergistically positive (Porter and Lawler, 1968). We confirmed that when people find activities inherently satisfying, it has a moderating effect on how motivated they become. However, even though one may expect that working remotely would automatically translate to higher motivation, this was not the case in the pandemic setting. This can be explained by the fact that remote working during the pandemic was externally regulated and the enforced confinement added to the stress created by the pandemic. Also, for many, working from home during the pandemic had negative implications for the management of the boundary between home and work.

The result shows that Remote Working intensity (RW) during the COVID-19 pandemic has a significant positive impact on Organisational factors (OF). Further, Employee's individual situation (ES) and Basic psychological needs satisfaction (PN) have a significant positive impact on Employee Motivation (EM). An employee's individual situation (ES) has a positive association with employee motivation. Stated differently, developments such as saving commuting time enabled employees to channel their energy and resources to get the job done while at home (Burell & Morgan, 2019).

The study found that remote working during the COVID-19 pandemic prompted the development of certain organizational practices, including measures for mental health support for employees. It concluded that the pandemic increased remote work intensity, and even though the infection rate of COVID-19 has abated, organizations are still open to remote working.

The result that basic psychological needs satisfaction (PN) has a significant positive impact on employee motivation corroborates the self-determination theory of motivation by Ryan & Deci (2000), which suggests that individuals have a natural tendency to grow and to self-organize. The satisfaction of psychological needs enhances the productivity of employees (Mullins & Christy, 2013). Adequate communication and information sharing with employees during the pandemic increased social connection and made them strive for superior performance.

Furthermore, providing assurance of job security, work flexibility, income stability, and conferring more responsibilities and confidence in employees during the pandemic were associated with increased motivation. Providing adequate training and allowing employees to use their initiative, among other considerations, will naturally keep employees focused and committed to their job (Chartered Management Institute, UK, 2020).

The significant positive association between organizational factors and the satisfaction of psychological needs (**Table 4.10; Model 2**) implies that organizations have a responsibility to ensure the satisfaction of the psychological needs of employees. This is especially important during periods characterized by fear and externally induced stress.

6. Strengths and Limitations

One limitation of this study is that it was carried out during the COVID-19 pandemic. The study shows the association between remote working, basic psychological needs satisfaction, and employee motivation during a crisis. How this motivation level varied amongst different working classes and demographic groups or the degree to which the outcome would change in the post-pandemic era remains unclear and should be an area for further study since motivation is not a unitary phenomenon.

Ethical Approval: All procedures performed in studies involving human participants were in accordance with the ethical standards of the institutional and/or national research committee and with the 1964 Helsinki Declaration and its later amendments or comparable ethical standards.

Informed Consent: Informed consent was obtained from all individual participants involved in the study.

Data Availability Statement: The datasets generated during and/or analyzed during the current study are available from the corresponding author (Charles Nwoko; charles.nwoko@phd.must.edu.my) on reasonable request.

Conflict of interest statement: The authors declare that they have no conflicts of interest.

Funding: The authors have not received any financial support for the research, authorship, and/or publication of this article.

References

- [1] Adel, C., Hussain, M.M., Mohamed, E.K.A., & Basuony, M.A.K. (2019). Is corporate governance relevant to the quality of corporate social responsibility disclosure in large European companies? *International Journal of Accounting & Information Management*, 27 (2), 301-332. <https://doi.org/10.1108/IJAIM-10-2017-0118>
- [2] Ajayi, P. I. (2020). Telecommuting During Covid-19 In Nigeria. *African Journal for the Psychological Study of Social Issues*, 23(2), 1–9
- [3] Alhassan, Z (2020). Teacher Motivation as a Catalyst for Enhancing Quality Education in Nigeria *International Journal of Operational Research in Management, Social Sciences & Education* | IJORMSSE p-ISSN: 2536-6521 | e-ISSN: 2536-653X. 6(1) April 2020
- [4] Amin A, Matthew W, Kafel W, Maryam B J (2021). Challenges and opportunities of remotely working from home during Covid-19 pandemic, *Global Transitions*, 3 99-108, ISSN 2589-7918, <https://doi.org/10.1016/j.glt.2021.11.001>. (<https://www.sciencedirect.com/science/article/pii/S2589791821000165>)
- [5] Arnold, C. (2018). *Pandemic 1918*. [S.l.]: St. Martin's Publishing Group.
- [6] Boddy, D. (2012). *Essentials of management: A concise introduction*. Pearson Education Limited.
- [7] Buallay, A., & Al-Ajmi, J. (2020). The role of audit committee attributes in corporate sustainability reporting: Evidence from banks in the Gulf Cooperation Council", *Journal of Applied Accounting Research*, 21(2). 249-264. <https://doi.org/10.1108/JAAR-06-2018-0085>
- [8] Burell, G. & Morgan, G. (2019), *Sociological Paradigms and Organisational Analysis: Elements of the Sociology of Corporate Life*. London Routledge
- [9] Burke, D., & Cocoman, A. (2020). Training needs analysis of nurses caring for individuals with an intellectual disability and or autism spectrum disorder in a forensic service. *Journal of Intellectual Disabilities and Offending Behaviour*, 11(1), 9-22. <https://doi.org/10.1108/JIDOB-10-2019-0024>
- [10] Cantarero, K., van Tilburg, W. A., & Smoktunowicz, E. (2020). *Affirming Basic Psychological Needs Promotes Mental Well-Being During the COVID-19 Outbreak*. <https://doi.org/10.31234/osf.io/pyhce>
- [11] Chapman, F. (2018). Managing emotional and psychological distress in older people. *Working with Older People*, 22 (4), 234-242. <https://doi.org/10.1108/WWOP-09-2018-0017>
- [12] Chartered Management Institute, UK (2020), *Managing the New Normal A Practical Guide to Navigating the Impacts of COVID-19, The Better Managers Manual*, Retrieved 10 May 2021 from: <https://www.managers.org.uk/wp-content/uploads/2020/07/better-managers-manual-2020-covid19.pdf>.
- [13] Dayrit, M.M., & Mendoza, R.U. (2020). Social cohesion vs. COVID-19. *International Journal of Health Governance*, 25 (3),191-203. <https://doi.org/10.1108/IJHG-03-2020-0022>
- [14] de la Fuente, A., Cardeñoso, O., Chang, E.C. (2022). The role of problem-solving ability, beyond academic motivation, in college students' psychological adjustment. *Curr Psychol*. <https://doi.org/10.1007/s12144-022-02945-y>
- [15] Deci, E. L., & Ryan, R. M. (1985). *Intrinsic motivation and self-determination in human behavior*. Perspectives in social psychology. New York: Plenum.
- [16] Eley, R.M. (2016). Telling it as it is: Involving people with dementia and family carers in policymaking, service design, and workforce development. *Working with Older People*, 20 (4), 219-222. <https://doi.org/10.1108/WWOP-09-2016-0026>
- [17] Erin, O. & Adegboye, A. (2021), Do corporate attributes impact integrated reporting quality? An empirical evidence, *Journal of Financial Reporting and Accounting*. ahead-of-print No. ahead-of-print. <https://doi.org/10.1108/JFRA-04-2020-0117>
- [18] Evans, S.C., & Bray, J. (2016). Best practice for providing social care and support to people living with concurrent sight loss and dementia: Professional perspectives. *Working with Older People*, 20 (2), 86-93. <https://doi.org/10.1108/WWOP-11-2015-0028>
- [19] Farooque, O.A., & Ahulu, H. (2017). Determinants of social and economic reportings: evidence from Australia, the UK and South African multinational enterprises, *International Journal of Accounting and Information Management*, 25. 177-200
- [20] Forson, J.A., Ofosu-Dwamena, E., Opoku, R.A. (2021). Employee motivation and job performance: a study of basic school teachers in Ghana. *Futur Bus J* 7, 30. <https://doi.org/10.1186/s43093-021-00077-6>
- [21] Funso, A; Sammy, L & Gerryshom, M (2016). Application of Motivation in Nigeria Construction Industry: Factor Analysis Approach, *International Journal of Economics and Finance, Canadian Center of Science and Education*, 8(5) 271-276
- [22] Gerged, A.M., Beddewela, E. & Cowton, C. (2021), Does country-level governance quality affect corporate environmental disclosure? Evidence from the Gulf Cooperation Council nations", *International Journal of Finance and Economics*, DOI: 10.1002/ijfe.2469.
- [23] Gethin-Jones, S. (2014). Familial perceptions of the impact of outcome-focused homecare on older people experiencing dementia and living alone. *Working with Older People*, 18 (2), 90-96. <https://doi.org/10.1108/WWOP-12-2013-0031>
- [24] Grigoropoulos, I., Daoultzis, K.C. (2022). Adverse Effects from the Imposition of Social Restrictions in Greece: the Indirect Effect of COVID-19-Related Fear on Alcohol Consumption Through Loneliness. *Trends in Psychol*. <https://doi.org/10.1007/s43076-022-00159-6>
- [25] Guido, G., Pichierri, M., Rizzo, C., Chieffi, V., & Moschis, G. (2020). Information processing by elderly consumers: A five-decade review. *Journal of Services Marketing*. <https://doi.org/10.1108/JSM-09-2019-0368>
- [26] Hamdan-Mansour, A., Al Shibi, A.N., Khalifeh, A.H., & Hamdan-Mansour, L.A. (2020). Health-care workers' knowledge and management skills of psychosocial and mental health needs and priorities of individuals with COVID-19. *Mental Health and Social Inclusion*, 24 (3),135-144. <https://doi.org/10.1108/MHSI-04-2020-0022>
- [27] Hu, L.-T., & Bentler, P. M. (1999). Cutoff criteria for fit indexes in covariance structure analysis: Conventional criteria versus new alternatives. *Structural Equation Modeling: A Multidisciplinary Journal*, 6(1), 1–55. <https://doi.org/10.1080/10705519909540118>.
- [28] Kumar, R (2011) *Research Methodology: a step-by-step guide for beginners*. Third Edition London: SAGE Publications Ltd
- [29] Legault, L. (2017). Self-determination theory. In V. Zeigler-Hill and T. Shackelford (Eds.), *Encyclopedia of Personality and Individual Differences*. New York, NY: Springer. http://link.springer.com/referenceworkentry/10.1007/978-3-319-28099-8_1162-1
- [30] Lu, J., & Wang, J. (2021). Corporate governance, law, culture, environmental performance, and CSR disclosure: A global perspective. *Journal of International Financial Markets, Institutions & Money*, 70 <https://doi.org/10.1016/j.intfin.2020.101264>
- [31] Mahmoud-Saleh, F.I., & Karia, N. (2020). Benchmarks for INGOs' effective responses during the COVID-19 pandemic. *Benchmarking: An International Journal*, 27 (10), 2863-2886. <https://doi.org/10.1108/BIJ-04-2020-0157>

- [32] Malhotra, A. (2021). The Postpandemic Future of Work. *Journal of Management*, 47(5), 1091–1102. <https://doi.org/10.1177/01492063211000435>
- [33] Mullins, L.J., & Christy, G. (2013). *Management and organizational behaviour*. Financial Times Publishing International.
- [34] Nagel, L. (2020). The influence of the COVID-19 pandemic on the digital transformation of work. *International Journal of Sociology and Social Policy*. <https://doi.org/10.1108/IJSSP-07-2020-0323>
- [35] Neuman, W. L. (2014). *Social research methods: Qualitative and quantitative approaches*. 7th Edition. Essex England Pearson Education Limited
- [36] Nuskiya, M.N.F., Ekanayake, A., Beddewela, E., & Gerged, A.M. (2021). Determinants of corporate environmental disclosures in Sri Lanka: the role of corporate governance. *Journal of Accounting in Emerging Economies*, 11 (3), 367–394
- [37] Nwobu, O. & Iyoha, F.O. (2018), Managerial perceptions of corporate sustainability reporting determinants in Nigeria, *Journal of Business and Retail Management Research*, 12(2) 72–82.
- [38] Offord, C. (2020). *How social isolation affects the brain*. The scientist. <https://www.the-scientist.com/features/how-social-isolation-affects-the-brain-67701>
- [39] Oliver, T., Murphy, J., & Cox, S. (2010). She can see how much I actually do! Talking Mats®: Helping people with dementia and family carers to discuss managing daily living. *Housing, Care and Support*, 13 (3), 27–35. <https://doi.org/10.5042/hcs.2010.0708>
- [40] Patanjali S, Bhatta NMK. (2022). Work from Home During the Pandemic: The Impact of Organizational Factors on the Productivity of Employees in the IT Industry. *Vision*. January. doi:10.1177/09722629221074137
- [41] Perego, P. and Kolk, A. (2012), Multinationals' accountability on sustainability: the evolution of third-party assurance of sustainability reports, *Journal of Business Ethics*, 110(2) 173–190
- [42] Porter, L. W., and Lawler, E. E. (1968). *Managerial Attitudes and Performance*. Homewood, IL: Irwin-Dorsey
- [43] Richard M. R. Edward L. (2000). Deci, Intrinsic and Extrinsic Motivations: Classic Definitions and New Directions, *Contemporary Educational Psychology*, 25(1) 2000 54–67, ISSN 0361-476X, <https://doi.org/10.1006/ceps.1999.1020>. (<https://www.sciencedirect.com/science/article/pii/S0361476X99910202>)
- [44] Ritche K. E. (2012). *Real Leaders Don't Boss*. Career Press.
- [45] Robson, C., & McCartan, K. (2016). *Real-world research: A resource for users of social research methods in applied settings*: 4th Edition. Chichester, UK: John Wiley & Sons.
- [46] Ryan, R. M. (2012). Motivation and the organization of human behavior: Three reasons for the re-emergence of a field. In R. M. Ryan (Ed.), *The Oxford handbook of human motivation* (3–10). Oxford University Press.
- [47] Ryan, R. M., & Deci, E. L. (2000). Self-determination theory and the facilitation of intrinsic motivation, social development, and well-being. *American Psychologist*, 55(1), 68
- [48] Ryan, R. M., & Deci, E. L. (2017). *Self-determination theory: Basic psychological needs in motivation, development, and wellness*. New York: The Guilford Press.
- [49] Šakan, D, Žuljević, D, Rokvić, N (2020), *The Role of Basic Psychological Needs in Well Being During the COVID-19 Outbreak: A Self-Determination Theory Perspective*. *Frontiers in Public Health*. Volume 8
- [50] Saunders, M., Lewis, P., & Thornhill, A. (2009). *Research methods for business students*. (5th ed.). Essex, England: Pearson Education.
- [51] Schreiber, J. B., Nora, A., Stage, F. K., Barlow, E. A., & King, J. (2006). Reporting structural equation modelling and confirmatory factor analysis results: A review. *The Journal of Educational Research*, 99(6), 323–338. <https://doi.org/10.3200/JOER.99.6.323-338>.
- [52] Shaughnessy, J.J, Zechmeister, E.B, & Zechmeister. J.S (2012), *Research methods in psychology*. 9th Edition New York, NY: McGraw-Hill,
- [53] Singh, N., Singh, S.B., Houssein, E.H., & Ahmad, M. (2020). COVID-19: Risk prediction through a nature-inspired algorithm. *World Journal of Engineering*, <https://doi.org/10.1108/WJE-08-2020-0358>
- [54] Sule, O.E; Amuni, S.I; Obasan, K.A & Banjo, H.A. (2015). Wages and salaries as a motivational tool for enhancing organizational performance. *A survey of selected Nigerian workplaces*. *EuroEconomica*, 1(34), 7–26
- [55] Szulawski M, Kaźmierczak I, Prusik M (2021) Is self-determination good for your effectiveness? A study of factors that influence performance within self-determination theory. *PLoS ONE* 16(9): e0256558. <https://doi.org/10.1371/journal.pone.0256558>
- [56] Tamunosiki-Amadi, J.O., & Dede, T. (2015). Self Determination and Employee Innovative Behaviour in the Nigerian Telecommunication Industry. *European Journal of Business and Management*, 7, 97–105.
- [57] Tauringana, V. (2020). Sustainability reporting adoption in developing countries: Managerial perception-based determinants evidence from Uganda. *Journal of Accounting in Emerging Economies*. <https://doi.org/10.1108/JAEE-07-2020-0184>
- [58] Tavakol, M., & Wetzell, A. (2020). Factor Analysis: a means for theory and instrument development in support of construct validity. *International journal of medical education*, 11, 245–247. <https://doi.org/10.5116/ijme.5f96.0f4a>
- [59] Thelwall, M., & Thelwall, S. (2020). A thematic analysis of highly retweeted early COVID-19 tweets: Consensus, information, dissent, and lockdown life. *Aslib Journal of Information Management*. <https://doi.org/10.1108/AJIM-05-2020-0134>
- [60] van Zoonen, W.; Sivunen, A.; Blomqvist, K.; Olsson, T.; Ropponen, A.; Henttonen, K. & Vartiainen, M. (2021). Factors Influencing Adjustment to Remote Work: Employees' Initial Responses to the COVID-19 Pandemic. *Int. J. Environ. Res. Public Health* 2021, 18, 6966. <https://doi.org/10.3390/ijerph18136966>
- [61] Vindegaard, N., & Benros, M.E. (2020). COVID-19 pandemic and mental health consequences: Systematic review of the current evidence. *Brain Behaviour Immunity*, 89, 531–542. <https://doi.org/10.1016/j.bbi.2020.05.048>
- [62] Vyas, L & Butakhieo, N (2021). The impact of working from home during COVID-19 on work and life domains: an exploratory study on Hong Kong, *Policy Design and Practice*, 4:7, 59–76, DOI: [10.1080/25741292.2020.1863560](https://doi.org/10.1080/25741292.2020.1863560)
- [63] Wang, B., Liu, Y., Qian, J., & Parker, S. K. (2020). Achieving Effective Remote Working During the COVID-19 Pandemic: A Work Design Perspective. *Applied psychology = Psychologie appliquee*, 10.1111/apps.12290. Advance online publication. <https://doi.org/10.1111/apps.12290>

[64] World Health Organisation, WHO (2012). WHO highlights global underinvestment in mental health care. *International Journal of Health Care Quality Assurance*, 25 (2), 1-2. <https://doi.org/10.1108/ijhcqa.2012.06225baa.002>

Appendices

Appendix 1: Measurement of Variables for the Study

Factors	Code	Observed Variables
Remote working during COVID-19 (RW) Raj (2021); Kropp et al. (2021)	RW1	Remote management of employees (Forbes et al., 2020)
	RW2	Additional support for working at home (Forbes et al., 2020)
	RW3	Experience from managing staff remotely (Forbes et al., 2020)
Organizational Factors (OF) Thomas (2020); CIPD (2020)	OF1	Mental health support (Rahimic, 2021)
	OF2	Teamwork and communication (De-la-Calle-Duran, 2021)
	OF3	Recognition and reward (Werder, 2020)
Basic Psychological Needs (PN) (Autonomy; Competence; Relatedness) (Deci and Ryan, 2017)	PN1	Ability to schedule tasks (Robinson, 2021)
	PN2	Independence and personal responsibility (Robinson, 2021)
	PN3	Training (Vyas & Butakhieo, 2021)
	PN4	Perceived organizational support (Mihalache & Mihalache, 2021)
	PN5	Supervisor accessibility (Mihalache & Mihalache, 2021)
	PN6	Appropriate crisis communication (Einwiller, Ruppel & Stranzl, 2021)
Employee's individual situation (ES) (Bradbury-Jones and Isham, 2020)	ES1	Family distraction (Kumar et al., 2021)
	ES2	Work-life domain (Vyas & Butakhieo, 2021)
	ES3	Stress-related consequences (Kniffin, 2020)

Appendix 2: Descriptive Statistics on Study Variables

	Min.	Max.	Mean	SD
1. Employees in my organization frequently worked from home before the COVID-19 pandemic	1	5	2.25	1.369
2. In my organization, employees worked primarily from home during the COVID-19 pandemic	1	5	4.25	1.017
3. Physical meetings are more effective compared to virtual meetings	1	5	3.12	1.291
4. Remote working had an effect on my work role and scope	1	5	3.35	1.197
5. It was easy for my organization to switch from working in the office to working remotely	2	5	3.71	.986
6. My organization is willing to allow employees to continue working remotely in the post-pandemic era	1	5	3.24	1.176
7. I depend on others to perform my work tasks	1	5	3.59	1.043
8. The COVID-19 pandemic accelerated the speed of deployment of remote working technology in my organization	2	5	4.06	.785
9. My supervisor/manager set clear expectations for me while I worked from home during the pandemic	1	5	3.82	.974
10. Compared to working in the office, I had fewer opportunities to request or receive informal performance feedback during the pandemic	1	5	3.20	1.040
11. Managing employees working remotely during the pandemic is different from managing employees working within the same office	2	5	4.18	.910
12. My leader trusts that I will put in my best even though I work remotely	2	5	4.06	.835
13. In my organization, employees' motivation levels changed during the COVID-19 pandemic	2	5	3.80	.800
14. Adequate IT tools and equipment were provided by my organization to support employees working from home during the pandemic	1	5	3.75	.935
15. The level of support provided by my organization towards employee mental health during the COVID-19 pandemic was satisfactory	1	5	3.37	1.076
"16. Employees in my organization were less engaged and committed while working remotely during the pandemic."	1	4	2.72	.882
"17. My organization provided adequate communication and information sharing during the pandemic."	2	5	4.08	.744
"18. I found the frequency of check-in sessions and employee follow-up during the pandemic satisfactory."	1	5	3.69	.905
"19. My organization provided assurance to employees that their jobs were secured during the pandemic."	2	5	4.00	.825
"20. My organization allowed employees to decide their work schedule while working remotely during the pandemic."	1	5	2.94	1.103
"21. The income I received from my employer changed during the COVID-19 pandemic."	1	5	2.48	1.249
"22. I was independent and personally responsible for my work while working from home."	1	5	3.90	.995
"23. My organization provided adequate training on how to use remote working and collaboration tools in order to assist my transition to working from home."	2	5	3.38	.987

"24. My supervisor/line manager was easily accessible to discuss any issues I had while working from home during the COVID-19 pandemic."	2	5	3.96	.727
"25. In my organization, we introduced some innovative measures to ensure social interaction amongst employees working remotely during the pandemic."	1	5	3.61	1.218
"26. My family situation affected my work schedule and performance while working from home."	1	5	2.78	1.282
"27. I put in more hours into my work because I saved some commuting time by working from home instead of the office."	2	5	4.18	.774
"28. Working from home created anxiety and stress for me."	1	5	2.57	1.208
"29. The process of transiting from working in the office to working from home was challenging for me."	1	5	2.58	1.214
"30. I had my dedicated personal workspace, which I did not have to share with others whilst working from home."	1	5	3.80	1.143
"31. I felt socially isolated whilst working from home during the pandemic."	1	5	2.88	1.227
"32. Working from home allowed me more time to attend to personal and family needs."	1	5	3.78	1.130
"33. I find the indoor environmental quality at home conducive for the performance of my work."	2	5	3.86	.881
"34. The flexibility of working from home improved my work performance."	2	5	3.76	.870
"35. I had better work-life balance while working from home compared to when I worked in the office."	2	5	3.72	1.051
"36. I got support towards my work from my family member(s) while working from home."	2	5	3.76	.870
"37. Given my personal and family situation, I would prefer to continue working from home."	1	5	3.72	1.107
"38. Caring for children and other family members while working from home affected my productivity."	1	5	2.60	1.050
"39. Continued working from home will negatively impact the pace of innovation in my organization."	1	5	2.88	1.211
"40. My physical and mental well-being was negatively affected when I worked from home."	1	5	2.24	.992
"41. Given the experience during the COVID-19 pandemic, my organization is willing to allow employees to continue working from home."	1	5	3.22	1.200
"42. I missed the opportunity to socialize with work colleagues because I worked from home during the pandemic."	1	5	3.50	1.129
"43. I feel accomplished when given the opportunity to decide my work schedule."	2	5	4.14	.764
"44. My enthusiasm and dedication towards my job remain the same even when I work from home."	2	5	4.18	.896
Valid N (listwise)				