RESEARCH ARTICLE

Economy and the Conflict with Uniformity in Syntactic Theory: The Case of Wh-Questions in Moroccan Arabic

Inass Announi¹ ✉ and Taoufik Allah Afkinich²

¹Doctoral student, Faculty of Languages, Letters, and Arts, English department, Ibn Tofail University, Kenitra, Morocco

²University Professor, Faculty of Languages, Letters, and Arts, English department, Ibn Tofail University, Kenitra, Morocco.

Corresponding Author: Inass Announi, **E-mail:** inass.announi@uit.ac.ma

ABSTRACT

This paper investigates the relevance of some syntactic principles in Generative Grammar. Specifically, the objective is to highlight the conflict between economy and uniformity in syntactic theory. This conflict is illustrated by some elements of wh-questions. Using the Minimalist Program as a current syntactic 'approach', we take MA wh-elements as a case study to test the relationship between the two principles. We, first, survey the importance of economy in the language itself. Second, we bring examples of the conflict in wh-interrogatives, specifically in wh-subjects, wh-objects, yes-no questions, and the [Q] feature. The significance of the research is that, in the absence of empirical evidence for uniformity, economy should be prioritized.

KEYWORDS

Wh-Questions, Moroccan Arabic, Economy, Uniformity, Generative Grammar, the Minimalist Program

ARTICLE DOI: 10.32996/ijllt.2022.5.3.18

1. Introduction and General Background

Language has always been considered a social fact. Indeed, the social dimension of language has always been present in the literature. This can be summarized in the following lines:

It is a treasure deposited by the practice of speaking in people belonging to the same community, a grammatical system that exists virtually in each brain, or more exactly in the brains of a collection of individuals; because the language is not complete in any individual, it exists perfectly only in the collective. (Saussure, 1916/1922, p. 30).

Starting from the 1950s, a refined language innateness theory was developed/suggested. To be more specific, Noam Chomsky wrote his *The Logical Structure of Linguistic Theory* in 1955, though he did not publish it until 1975. Syntactic theory was seen from a completely different angle:¹

Linguistic theory is concerned primarily with an ideal speaker-listener, in a completely homogeneous speech-community, who knows its language perfectly and is unaffected by such grammatically irrelevant conditions as memory limitations, distractions, shifts of attention and interest, and errors (random or characteristic) in applying his knowledge of the language in actual performance. (Chomsky, 1965, p. 3).

The debate between the social and cognitive perspectives can be compared to that between those who lean to either studying language as a form of output (i.e., performance) or input (i.e., competence) (Chomsky, 1965, p. 4).

¹ Note that the cognitive dimension of language was popularized in the 1950s but existed way before that (e.g., Wundt, 1900).

For the latter, the central question that needs to be answered is the following: How do children, at a fast pace, with limited exposure to language, and in a pretty uniform way acquire their mother tongue and produce from a finite set of data an infinite number of utterances? This question is often called the Logical Problem of Language Acquisition or 'discrete infinity' (Chomsky, 2005, p. 11). By answering this question, syntacticians will minimize the language acquisition burden on the child and, consequently, maximize the learnability of grammar (Chomsky, 1995). This is summarized in the so-called Universal Grammar (henceforth UG) (Chomsky, 1965). UG is "the theory about the mental procedure implicit in [the I-language]" (Uriagereka, 1998, p. 36). Since the child acquires language quickly and produces an infinite number of utterances from limited data, we need a syntactic theory to replicate the same process as the child (i.e., our grammar or theory needs to be explanatorily adequate). In other words, according to Chomsky (2015), any 'natural' science aims to catch the simplicity of nature. Since language is a perfect system, then the theory that explains language should also reflect a perfect design in the form of the most uncomplicated grammar (Chomsky, 1995). This simplicity is embodied in UG, which needs to encourage the most economical computational operations.² For this reason, Chomsky (1998, p. 9) states that language is "an optimal solution to legibility conditions." Thus, economy³ is one of the most central elements in the current syntactic theory. Our paper is divided as follows: the second section tries to search for the signs of economy on language itself. The third section investigates the conflict between economy and uniformity, taking *wh*-questions in Moroccan Arabic (henceforth, MA) as a case study. Our main objective is to question whether the concept of 'economy' plays a role in the syntactic theory, especially if it clashes with other principles such as uniformity.

2. Economy and its Signs on the Language Itself

Syntactic theory gives importance to economy because language itself displays this phenomenon. A first example is the three economy principles of Move that languages show in general. These are Last Resort, Greed, and Procrastinate. First, the Last Resort principle is a "condition of movement (which) requires that movement is permitted only to satisfy some condition" (Chomsky, 2015, p. 41). In other words, Last Resort happens when "Move F raises to target K only if F enters into a checking relation with a sublabel of K" (Chomsky, 1995, p. 280). This principle motivates the movement of elements. If the operation can occur without movement, then Move need not happen; hence, movement is a last resort or option. An example of this is *wh*-movement in MA, where *wh*-elements do not stay in-situ and must move (Nouhi, 1996; Announi, 2019, 2021). Second, Last Resort is later modified to become Greed (self-serving Last Resort), which means that "benefiting other elements is not allowed"⁴ (Chomsky, 2015, p. 184). Let us take the following example (Chomsky, 2015, p. 239):

- (1) seems [(that) John is intelligent]
 (2) *John seems [(that) *t* is intelligent]

John moves to the matrix clause to satisfy the Extended Projection Principle (EPP) (i.e., the subject position is unfilled) and Case. However, the principle of Greed does not allow movement since *John* already satisfied EPP and Case in the embedded clause. Finally, Procrastinate (Chomsky, 1991, 1992) permits delaying movement whenever possible. Chomsky (2015, p. 181) states that "LF movement is 'cheaper' than overt movement." Delayed movements are covert movements where elements that did not move in overt syntax move at the covert syntax. An example of this is English, where main verbs do not move until after the Spell-Out (Pollock, 1989) and *wh*-questions in EA (Gad, 2011), where they stay in-situ. These three principles show how languages are given different options to convey elements of economy.

A second example of the sign of economy on language itself is feature stranding. To explain this phenomenon, let us bring these two examples:

- (3) ʃnu taddir **Moroccan Arabic**
 What do.2P
 'What are you doing?'
- (4) ʔenta tiʃmil ʔih **Egyptian Arabic**
 You do.2P what
 'What are you doing?'

There are two options for the movement of elements concerning features (Chomsky, 2015, p. 242). The first option is for syntactic elements to move with the feature that needs checking; this process is called pied-piping. For example, in MA (see, e.g., 3), the [Q] feature moves with the *wh*-elements to be checked (Chomsky, 2015, p. 125). The second option is that syntactic elements stay in-situ while the feature that needs checking moves in the covert syntax; this process is called stranding. For example, the [Q] feature

² This is often referred to as the Strong Minimalist Thesis (Chomsky, 1998, 2005).

³ Note that economy is not new in the sciences. This is similar to the law of parsimony, a principle that states the preference of the simplest explanation of phenomena and/or the simplest solution to a problem (Gauch, 2003).

⁴ For the sake of removing ambiguity, when we say that Last Resort is costly, we insist that 'costly' refers only to convergent derivations (Uriagereka, 1998, p. 343).

moves in Egyptian Arabic while the wh-element stays in-situ (Chomsky, 1995). Feature stranding is an example of a procedure where it is more economical to leave a wh-element behind than to move them along with the feature in question.

A final example of economy in languages is the Attract Closest Principle, which entails that “a head which attracts a given kind of constituent attracts the closest constituent of the relevant kind” (Radford, 2004, p. 162). Let us look at the following examples:

- (5) /ʃkun kla ʃnu
 who ate what
 ‘Who ate what?’
 (Announi, 2019, p. 95)
- (6) *ʃnu ʃkun kla
 What who ate

Both (5) and (6) are examples of multiple wh-construction. In MA, multiple wh-questions are possible but only as echo-questions (Announi, 2019). We observe that while it is correct to front one wh-element (see 5), it is ungrammatical to front both wh-elements to the left periphery. Let us show example (6) in the form of a tree representation to explain its ungrammaticality:

(7)

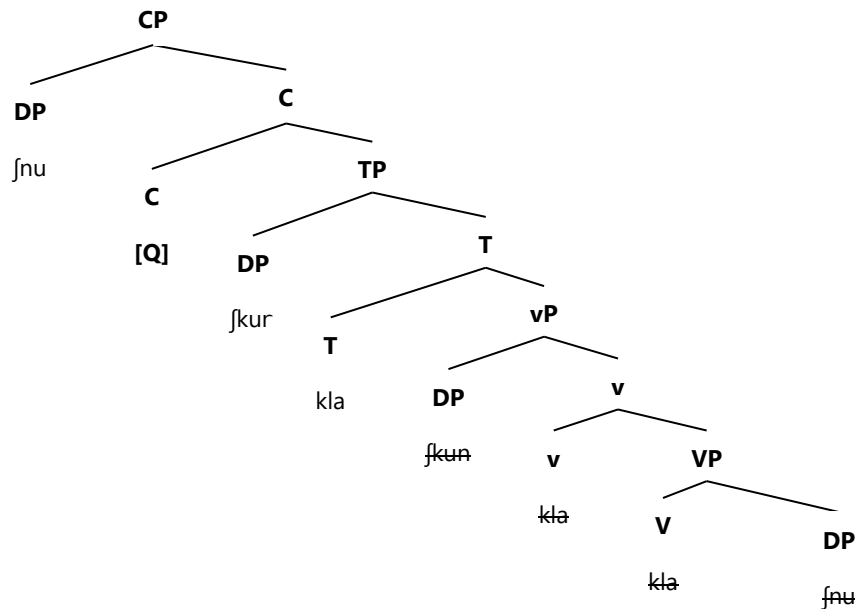

According to Attract Closest Principle, the head C needs to attract the closest element to it. In our example, the wh-element /ʃkun/ *who* is closer than /ʃnu/ *what*. Thus, (6) is ungrammatical because it selects the wh-object further apart from the wh-subject. This principle is an example of economy wherein language prefers to front the closest element to the head in question.

This section highlighted examples of economy in the language itself. The following section will look closer at the relationship between economy and uniformity.

3. The Conflict between Economy and Uniformity: The Case of Wh-Questions

This section will sketch the relationship between economy and uniformity. It looks at the cases where economy and uniformity clash. These cases are wh-subjects, yes-no particles, wh-objects, and the [Q] feature. We will conclude the section by looking at a case of multiple wh-questions where neither economy nor uniformity work.

3.1 The Conflict between Economy and Uniformity: The Case of Wh-Subjects

Consider the following example:

- (8) [CP]ʃkun [C]li kla t-tffaħa
 who that ate the-apple
 ‘Who is it that ate the apple?’

According to Announi (2019, pp. 72-74), wh-subjects in MA move from [Spec, TP] to [Spec, CP] to check the [Q] and [EPP] features. The empirical evidence for the movement lies in the presence of the complementizer /lli/ *that*. This shows that wh-subjects must be to the left of the complementizer:

(9)

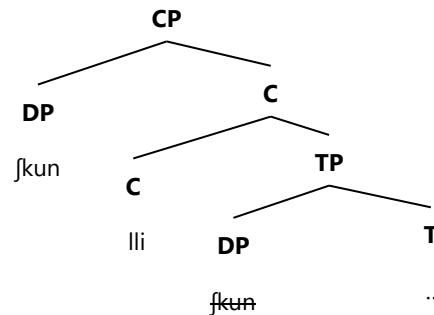

However, consider this example:

(10) ʃkun kla t-tffaħa
 who that ate the-apple
 'Who ate the apple?'

With the absence of the complementizer, we are left with two options. We either (a) move the wh-subject /ʃkun/ *who* to [Spec, CP], or (b) the wh-subject stays in [Spec, TP]. These two examples illustrate the clash between uniformity (a) and economy (b). On the one hand, if we want to achieve uniformity, all wh-elements should move to [Spec, CP] (see 11a. below). If we make wh-subjects an exception, then we risk not implementing the principle of uniformity. On the other hand, if we want to achieve economy, wh-subjects do not have to move to [Spec, CP] and can simply stay in [Spec, TP] (see 11b. below):

(11)

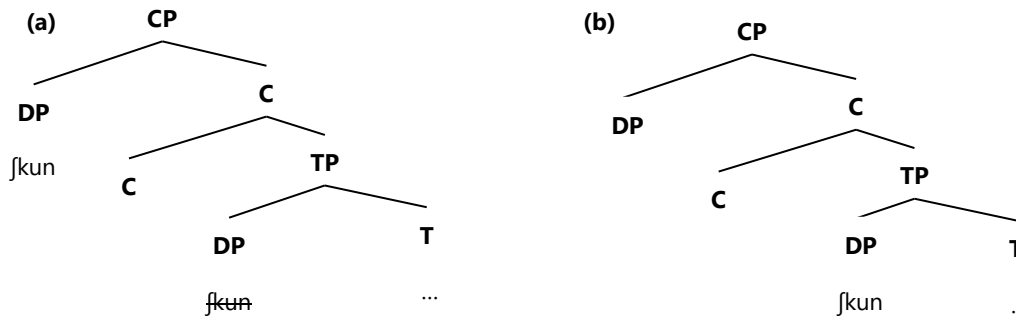

The economy proponents call this the Vacuous Movement Hypothesis (Chomsky, 1986b; see also Nouhi, 1996 for MA; Al-Momani & Al-Saidat, 2010 for Jordanian Arabic). We also refer to the Lexical Clause Hypothesis (Fukui & Speas, 1986). It states that subjects, not verbs, do not have to move and can be base generated.

One question we ask is, what does the syntactic theory choose nowadays? If we follow the generative grammar's primary objective, the theory should aim for economy. However, generative syntacticians argue for uniformity and bring evidence for their preference. First, all wh-elements need to move to [Spec, CP] to check the [Q] and [EPP] features. Even if we assume that wh-elements' [Q] feature can still be checked in [Spec, TP], the [EPP] feature (or the Edge Feature; Chomsky, 2005) demands that [Spec, CP] needs to be filled by a subject. Second, some languages can check their features without elements moving to the landing site (e.g., Icelandic and English; Soltan, 2007). Finally, nowadays, syntacticians argue for the movement of all wh-elements to [Spec, FocusP] to check the contrastive feature [Foc] (see Alotaibi, 2013 for Standard Arabic; Gad, 2011 for Egyptian Arabic; Al-Momani & Al-Saidat, 2010 for Jordanian Arabic; Fakihi, 2014, for Najrani Arabic). This proposal will eliminate the issue of the wh-subject staying in [Spec, TP] because all wh-elements express focus and need to move to [Spec, FocusP].

As we can see, there is an apparent clash between the two principles of economy and uniformity. With all of these taken into account, we propose that when the wh-subject appears with the complementizer, then uniformity overrides economy. When the wh-subject does not occur with the complementizer, economy overrides uniformity.

3.2 The Conflict between Economy and Uniformity: Yes-No Particles

Consider examples from English, Standard Arabic, and MA:

- (12) Did you study today? **English**
- (13) hal qaraʔt-a I-jawma **Standard Arabic**
 Q-Prt read.PAST-2P the-today
 'Did you study today?'
- (14) waf qrit-i I-juma **Moroccan Arabic**
 Q-Prt read.PAST-2P the-today
 'Did you study today?'

(12), (13), and (14) are yes-no interrogative sentences in English, Standard Arabic, and MA. In English, yes-no question formation results from T-to-C movement (Chomsky, 1995). Let us look at the figure below:

(15)

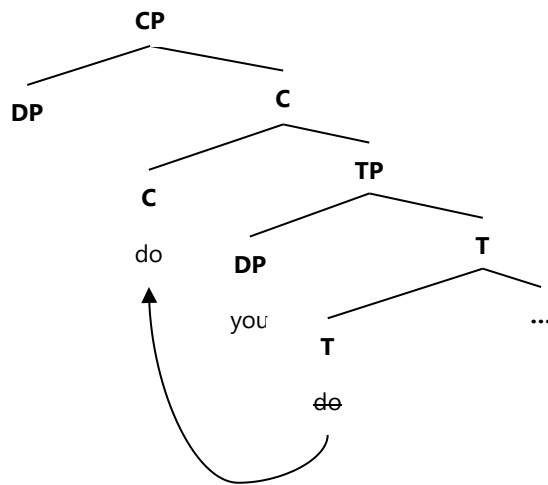

As shown in (15), yes-no question formation is the result of the verb moving from the T(ense) to C(omplementizer) position (Chomsky, 1995). Let us now turn to Standard Arabic:

(16)

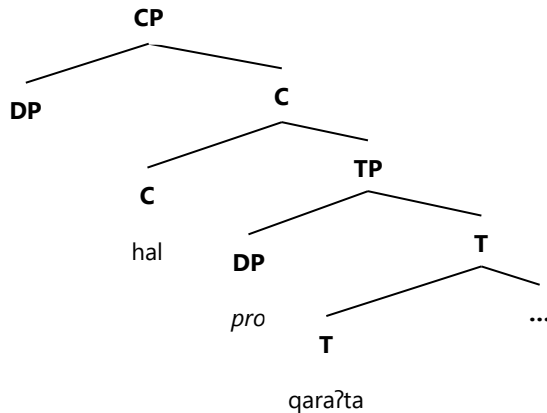

In Standard Arabic, the question particle /hal/ is base generated in C; this is because yes-no questions in SA do not force any morphosyntactic operation (i.e., subject-verb inversion) and are, thus, only base generated in C (Fakih & Al-Dera, 2014). MA also

does not force subject-verb inversion. The obvious conclusion is, then, that the yes-no particle /waf/ is base generated. Moreover, Announi (2019) questions whether the yes-no question is base generated in C or in [Spec, CP] as seen below:

(17)

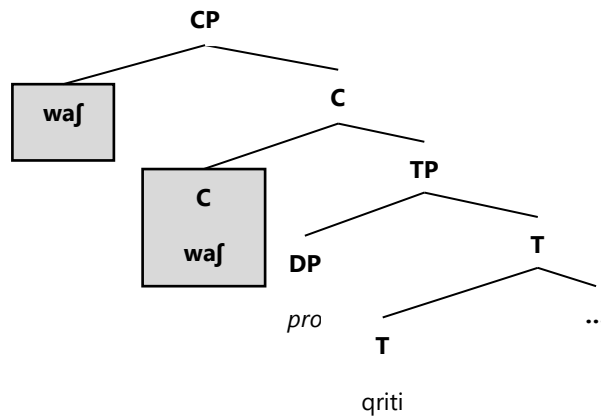

Whether the yes-no particle is base generated in C or [Spec, CP] is a classic problem of the clash between economy and uniformity. If we would like to achieve uniformity, all interrogatives (i.e., yes-no particles and wh-questions) are positioned in [Spec, CP]. This provides rule unification for question formation. If we would like not to confuse the structure (i.e., achieve economy), then yes-no interrogatives should be situated in C while wh-questions should be in [Spec, CP]. A simple and economical structure provides a clear meaning to the structures. Semantically, yes-no questions and wh-questions differ; therefore, the structure should distinguish between the two. Empirically speaking, data suggest that uniformity overrides economy. Consider the following examples from Announi (2019, p. 56):

(18) waf ila fəfti-ha yedda, ɣa-tʒi ʃənd-i?
 Q-Prt if see-3SG.F tomorrow, FUT-come.2SG to-me
 'If you see her tomorrow, will you come to me?'

/ila/ if occupies C. This means that /waf/ is in a position higher than C. This position is [Spec, CP]. There is empirical evidence that the yes-no particle precedes the complementizer /lli/ that (Announi, 2019, p. 56, e.g., 2). Therefore, yes-no question formation provides evidence for the clash between economy and uniformity.

3.3 The Conflict between Economy and Uniformity: The Case of Wh-Objects

Let us turn our attention to wh-objects:

(19) ʃnu qriti l-juma
 what read.PAST-2P the-today
 'What did you study today?'

There are two options for the initial position of objects. Let us look at the figure below:

(20)

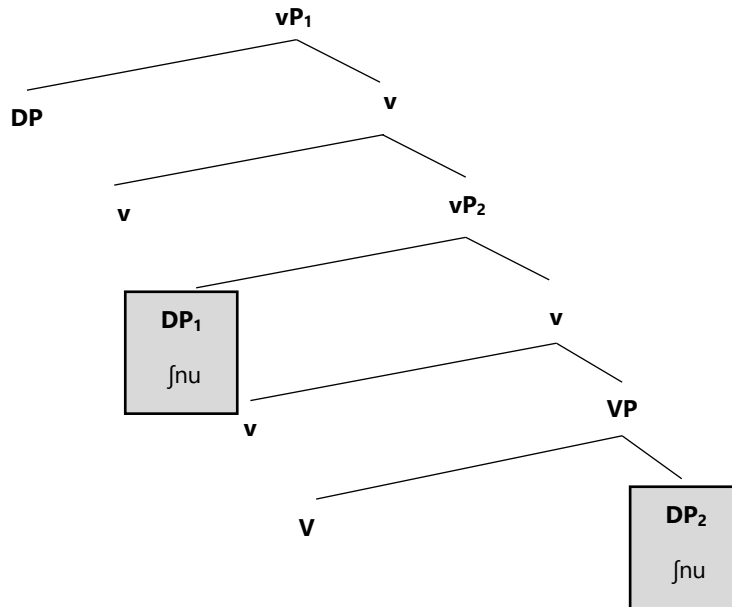

The first option is that the wh-object DP₂ will be externally merged with the verb. The second option is the wh-object is in Spec-head relation with v. In this situation, we have two vPs: one for the wh-subject position, the outer shell vP₁, and one for the wh-object position, the inner shell vP₂. These two options are the result of a clash between uniformity and economy. If we prioritize uniformity, then the specifier proposal is the right one since both subjects and objects will be situated in the specifier of the verb phrase. If economy is prioritized, the wh-object can simply be externally merged with the verb, and there is no need for an extra projection. In the current syntactic theory, Uriagereka (1998) selects the external merge proposal because it is the cheapest, most economical option. Another reason for economy overriding uniformity in this situation is that the specifier proposal violates the Shortest Move principle; that is, the direct object moves across the subject in [Spec, vP₂] to [Spec, vP₁] but the subject in [Spec, vP₂] is the closest element to [Spec, vP₁] (Musabhién, 2008, p. 75). This situation is, however, solved by Chomsky (1995, p. 356), who proposes the Equidistance principle: the idea that if the object and subject are within the same minimal domain, then [Spec, vP₁] is accessible by the object and the subject and the inner shell will not block movement. This also explains why subjects moving to [Spec, TP] is not blocked by the outer shell (Musabhién, 2008, p. 76). One can claim that even if the situation is solved, the economy option is better since, in the absence of empirical evidence for uniformity, economy should be prioritized. It should be noted that the current syntactic theory (the Minimalist Program; Chomsky, 2005) prioritizes uniformity. That is, if the wh-object stays in the complement position, the derivation will crash since as soon as the TP is introduced, VP will be shipped to PF and LF.

3.4 The Conflict between Economy and Uniformity: The Issue of the [Q] Feature

In the case of wh-elements. The [Q] feature interprets the interrogativity of the sentence. The following questions arise:

1. Do wh-elements have the [Q] feature in the lexicon?
OR
2. Do wh-elements incorporate the [Q] feature until they reach the computational system?

The positive answer for question 1 means that uniformity overrides economy. That is, all wh-elements, without any exception, will have the [Q] feature in the lexicon. On the contrary, if question 2 has an affirmative answer, then not all wh-elements have the [Q] in the lexicon, and wh-elements wait until the derivation to incorporate the [Q] feature. There are many pieces of evidence provided by Zavitnevich-Beaulac (2005), which champion economy over uniformity. Consider the following example:

(21) ma-ʃraʔt-ʃ ʃnu qriti l-juma
 Neg-know-Neg what read.PAST-2P the-today
 'I do not know what you studied today.'

If we assume that [Q] is an inherent feature integrated into wh-elements in the lexicon, how can we explain the appearance of wh-elements in affirmative sentences? In (21), the wh-object appears in affirmative sentences. If the [Q] is present in the lexicon, how do we explain wh-elements appearing in non-interrogative sentences? If the [Q] feature is introduced to (21), it will not be checked against C since the sentence does not introduce an interrogative force.

Announi (2019) solved the issue by stating that there are two distinctive features: [Q] and [WH]. The [Q] feature shows that the sentence is interrogative while the [WH] feature shows the existence of a wh-question. This means that wh-elements do not have the [Q] feature in the lexicon but arrive at the computational system when needed to express the interrogativity of the sentence. This also means that the [WH] feature is the inherent one. Consider this example:

(22) *ʃkʊn qra ʃnu*
 who read what
 'Who read what?'

The second evidence is the case of multiple wh-questions. In the case of (22), does that mean each wh-element has its own [Q] feature to interpret the sentence as interrogative? Only one contributes to the interrogativity of the sentence. If we argue for uniformity, both wh-elements will come with uninterpretable [Q] features. While one of them will be checked against C (i.e., the wh-subject), what will happen to the [Q] feature on the wh-object? This will cause the derivation to crash. The natural conclusion is that the [Q] features arrive until the computational system.

It gets even worse if we consider our third evidence. What happens to Slavic languages such as Hungarian, which fronts all of its wh-questions in the left periphery. Does that mean all of those questions have the [Q] feature or just one of them? It seems that the economy proposal will solve this problem more than the uniformity one.

A final piece of evidence is when it comes to the nature of wh-elements. It is not always the case that wh-elements express interrogativity, whether direct or indirect. Wh-elements can also be relatives, indefinites, and quantifiers in other languages.

To sum up, it is more economical for the [Q] feature to appear until the computational system since not all wh-elements possess the [Q] feature in the lexicon.

We discussed cases where economy is in apparent conflict with uniformity. Before we end the paper, let us discuss the issue of wh-questions one final time. Economy dictates that we do not need to move wh-elements. This shows that economy is not always attested in languages. For example, in MA, it uses wh-movement as a default strategy while languages such as Chinese conform to economy by having wh-elements stay in-situ. Now, if all wh-questions stay in-situ, then we conform by both economy and uniformity. Economy works since all wh-questions do not have to move. Uniformity works since all wh-questions stay without others moving. Languages such as MA and English display a dilemma. Only one wh-question moves to the left periphery while the other remains in-situ. In this case, neither economy nor uniformity work in MA multiple wh-construction. The situation worsens with the so-called optional wh-movement languages (e.g., Egyptian Arabic; Gad, 2011), where wh-elements can stay in-situ and optionally front to the left periphery. By taking everything into account, we conclude that there is an evident clash between economy and uniformity. If there is empirical evidence for selecting uniformity, then it overrides economy; otherwise, economy should be prioritized.

5. Conclusion

This paper discussed the principle of economy and its relation to uniformity. We took MA wh-elements as a case study to test the relationship between the two principles regarding wh-subjects, wh-objects, yes-no questions, and the [Q] feature. We also noted a case where neither economy nor uniformity work in MA. Our final remark is that when there is a clash between economy and uniformity, and if there is empirical evidence for uniformity, we should pick it. In the absence of empirical evidence and we have the option for economy, syntactic theory should opt for economy since it should reflect language acquisition. One limitation for the study is that we did not explore further syntactic phenomena, apart from wh-questions, in order to further prove this conflict and the prioritization of economy in the absence of empirical evidence. Implications for future research include the need to further investigate the relationship between the two principles in the light of other syntactic structures.

Funding: This research was funded by the National Center for Scientific and Technical Research, grant number 2UIT2020.

Conflicts of Interest: The authors declare no conflict of interest.

ORCID iD: Inass Announi <https://orcid.org/0000-0003-0076-7589>

References

- [1] Al-Momani, I., & Al-Saidat, E. (2010). The Syntax of wh-movement in Jordanian Arabic, *European Journal of Scientific Research*, 40(4), 609-636.
- [2] Alotaibi, M. (2013). A problem with wh-questions in Modern Standard Arabic. *Proceedings of language at the University of Essex*, 1-8.
- [3] Announi, I. (2019). *Wh-Elements in Moroccan Arabic: A Minimalist Approach* [Unpublished Master's thesis]. Ibn Tofail University.
- [4] Announi, I. (2021). The problem of word order and verbal movement in Moroccan Arabic. *International Journal of Linguistics, Literature and Translation*, 4(4), 34-54. <https://doi.org/10.32996/ijllt.2021.4.4.6>

- [5] Chomsky, N. (1965). *Aspects of the theory of syntax*. MIT Press.
- [6] Chomsky, N. (1986a). *Knowledge of language: Its nature, origin, and use*. Praeger.
- [7] Chomsky, N. (1986b). *Barriers*. MIT Press.
- [8] Chomsky, N. (1991). Some notes on economy of derivation and representation. In R. Freidin (Ed.), *Principles and Parameters in Comparative Grammar* (417-454). MIT Press.
- [9] Chomsky, N. (1992). A minimalist program for linguistic theory. *MIT Occasional Papers in Linguistics, 1*. MIT Working Papers in Linguistics.
- [10] Chomsky, N. (1995). *The Minimalist Program*. The MIT Press.
- [11] Chomsky, N. (1998). Minimalist inquiries: The framework. In R. Martin, D. Michaels & J. Uriagereka (Eds.), *Step by Step: Essays on Minimalism in Honor of Howard Lasnik* (pp. 89–155). MIT Press.
- [12] Chomsky, N. (1999). Derivation by phase. *MIT Occasional Papers in Linguistics, 18*. MIT Working Papers in Linguistics.
- [13] Chomsky, N. (2000). Minimalist inquiries: The framework. In R. Martin, D. Michaels, J. Uriagereka & S. J. Keyser (Eds.), *Step by step: Essays on minimalist syntax in honor of Howard Lasnik* (pp. 89-155). MIT Press.
- [14] Chomsky, N. (2005). Three factors in language design. *Linguistic Inquiry, 36*(1), 1–22.
- [15] Chomsky, N. (2015). *The Minimalist Program* (20th anniversary ed.). The MIT Press.
- [16] De Saussure, F. (1922). *Cours de linguistique générale* [Course in general linguistics] (Trans. Roy Hariss). Paris: Payot. (Original work published 1916).
- [17] Fakh, A. (2014). Subject wh-movement in Najrani Arabic and Minimalism. *International Journal of Linguistics, 6*(5) 90-108.
- [18] Fakh, A. A. & Al-Dera, S. A. (2014). Question affix analysis in Standard Arabic: A Minimalist perspective. *International Journal of English Linguistics; 4*(6), 1-15.
- [19] Fukui, N. & Speas, M. (1986). Specifiers and Projections. MIT Working Papers in Linguistics, 8. Cambridge: Department of Linguistics and Philosophy, MIT.
- [20] Gad, R. F. (2011). *A syntactic study of wh-movement in Egyptian Arabic within the minimalist program* (Publication No. 540560) [Doctoral dissertation, University of Leeds]. <https://etheses.whiterose.ac.uk/5397/>
- [21] Gauch, H. G. (2003). *Scientific method in practice*. Cambridge University Press.
- [22] Langacker, R. W. (1987). *Foundations of cognitive grammar (Vol. 1): Theoretical prerequisites*. Stanford University Press.
- [23] Musabhien, M. (2008). *Case, agreement and movement in Arabic: A minimalist approach*. Newcastle University.
- [24] Nouhi, Y. (1996). *Wh-constructions in Moroccan Arabic* [Master's thesis, University of Ottawa]. Retrieved June 2021 from <http://hdl.handle.net/10393/9463>.
- [25] Radford, A. (2004). *English syntax: An introduction*. Cambridge University Press.
- [26] Soltan, U. (2007). *On formal feature licensing in Minimalism: Aspects of Standard Arabic morphosyntax* [Doctoral dissertation, University of Maryland]. <http://hdl.handle.net/1903/7581>
- [27] Uriagereka, J. (1998). *Rhyme and reason: An introduction to minimalist syntax*. The MIT Press.
- [28] Wundt, W. (1900). *Die Sprache*. Englemann.
- [29] Zavitnevich-beaulac, O. (2005). On wh-movement and the nature of wh-phrases – Case Re-Examined. *Skase Journal of Theoretical Linguistics, 2*(3), 75–100.